

2016 MASTER CATALOGUE



ACCURATE
SCREEN + GRATING
Products with holes, backed with solid service



CONTENTS

CUSTOM FABRICATION	Page 1
PERFORATED METAL	Page 5
Round Staggered Pattern	Page 6
Round Inline Pattern	Page 8
Square Inline Pattern	Page 9
Slotted Pattern	Page 10
Decorative Pattern	Page 11
WELDED MESH	Page 13
WOVEN MESH	Page 17
EXPANDED METAL	Page 25
Expanded Metal - Flat	Page 26
Expanded Metal - Raised	Page 28
Expanded Grating	Page 30
BAR GRATING	Page 33
Bar Grating Treads	Page 38
FIBREGLASS GRATING	Page 39
Fibreglass Grating Treads	Page 42
CHANNEL GRATING	Page 43
Diamond Channel	Page 44
Round Channel	Page 46
Walkway Channel	Page 48
Dimple Channel	Page 49
Channel Grating Treads	Page 50
Ladder Rungs	Page 52
ALUMINUM DECKING, CLADDING & NON-SLIP FLOORING	Page 53
Aluminum Decking	Page 54
Aluminum Cladding	Page 55
Non-Slip Flooring (Dimple Plate, X-Deck & Fibreglass Plate)	Page 56
TIE WIRE, STEEL BANDING & FASTENERS	Page 59
Tie Wire & Banding	Page 60
Fasteners	Page 61
ARCHITECTURAL METAL	Page 67

CUSTOM FABRICATION

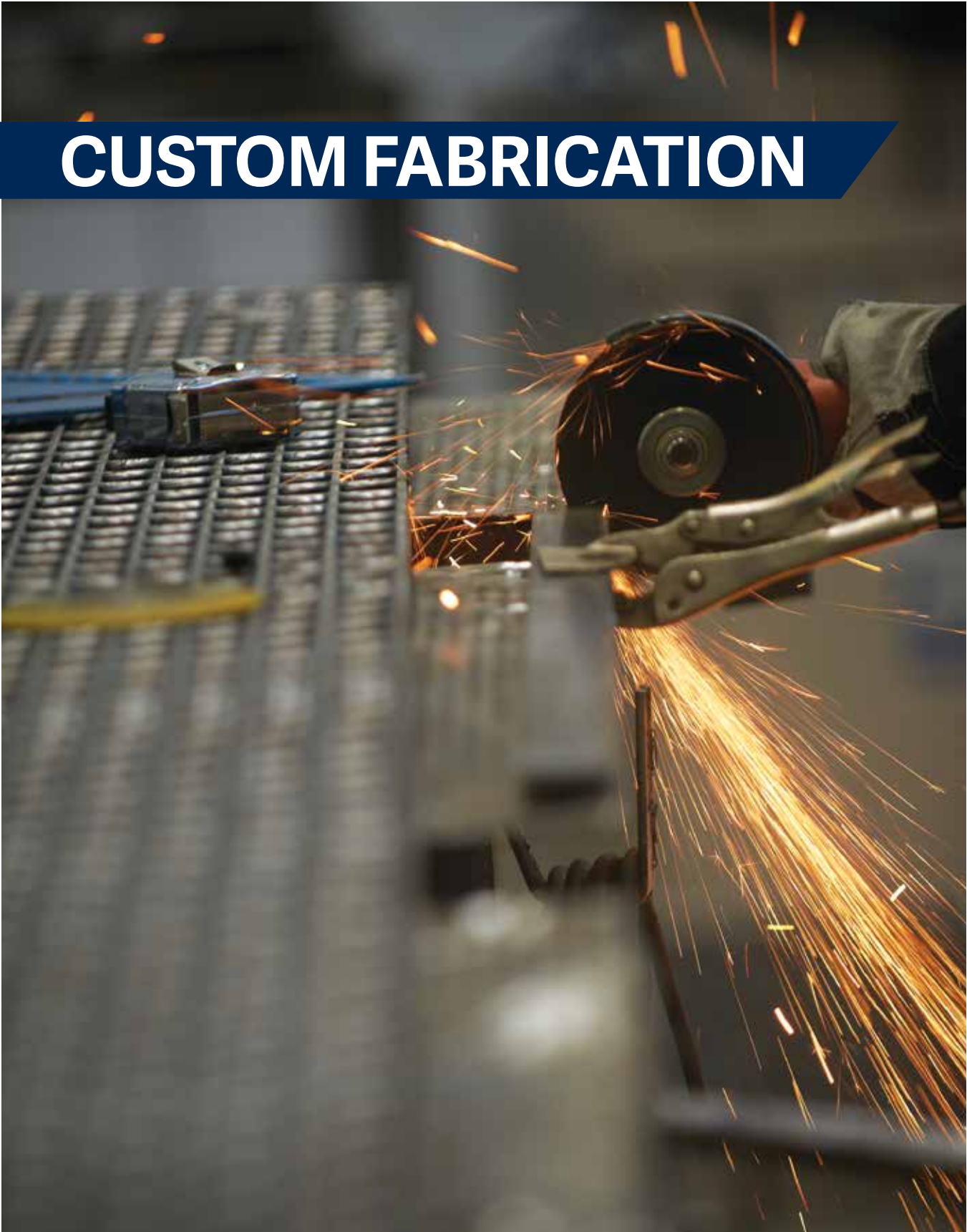

Custom Fabrication

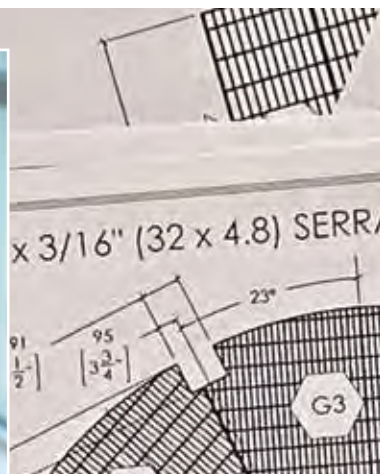
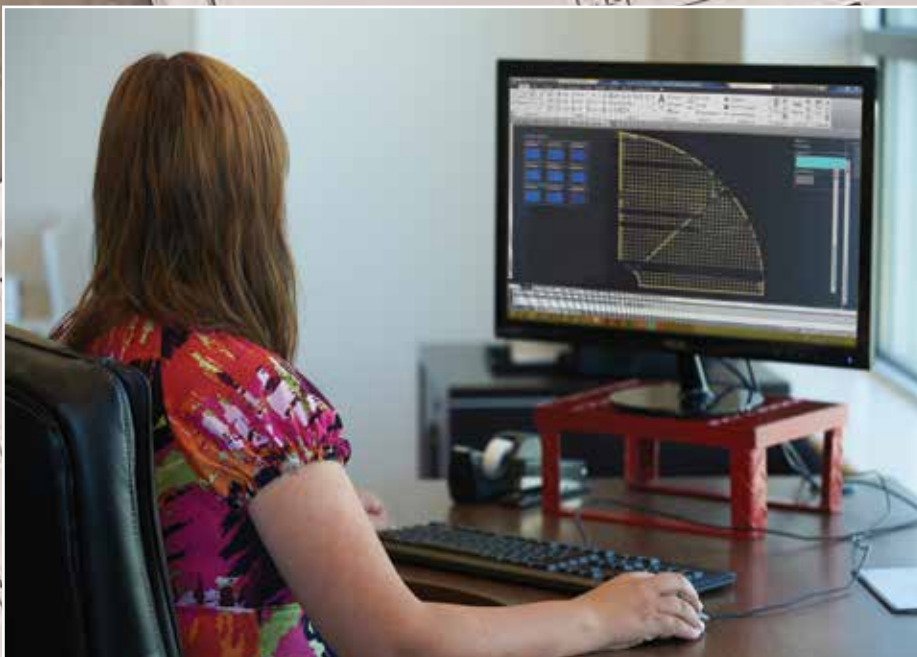

Custom Fabrication



BEA
SCRA
1-1/4"

HANDING:
1-1/2" x 3/16"
PEDESTRIAN L
12 OUTSIDE BEA
THIRD BAR IN BE

SH
RANGED

PER TOLERANCES
& CUTOUTS

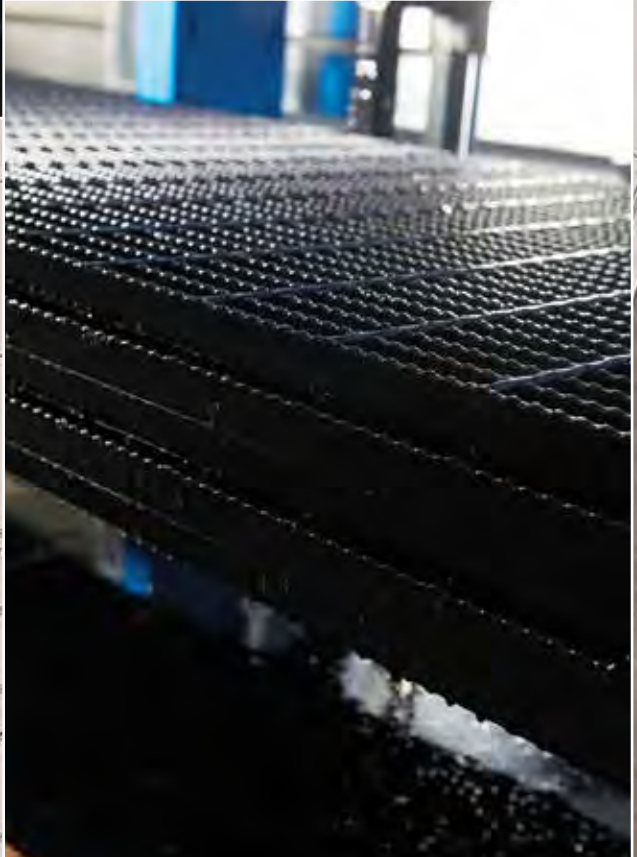

Custom fabrication has become a substantial portion of our business. To meet the ever growing demand for our custom fabrication service we have equipped our plants with the best machinery available for cutting, forming and welding. Along with the best equipment we have also made a commitment towards staffing our fabrication areas with highly skilled tradespeople. Quality materials, the best equipment available and skilled people produces the exact results our customers expect.

Grating treads, landings and walkways makeup a large portion of our fabrication. However, we also do many other custom fabrication projects such as: mesh infill panels, welded mesh industrial fan guards, window applications and security screening.

If your project requires custom fabrication, speak to your ASG Sales Representative. They will work with you to provide a fabricated solution that meets your expectations.

TA
4E

DVA

RTY OF
ERTA III

PLATFORM & GRATING

0: Februar
: GS

WELDED

CUSTOMER:
/ 50P

TING

Fabrication Gallery

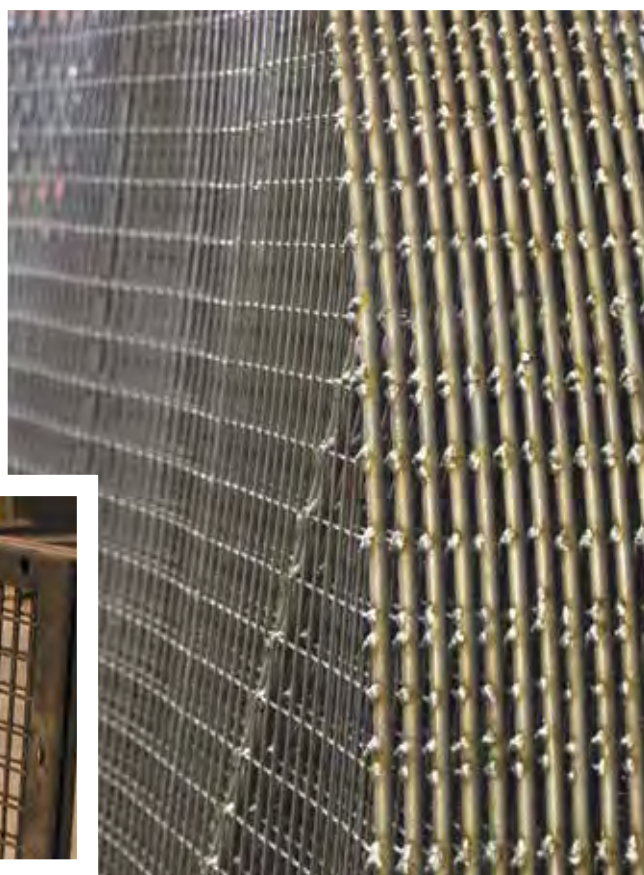
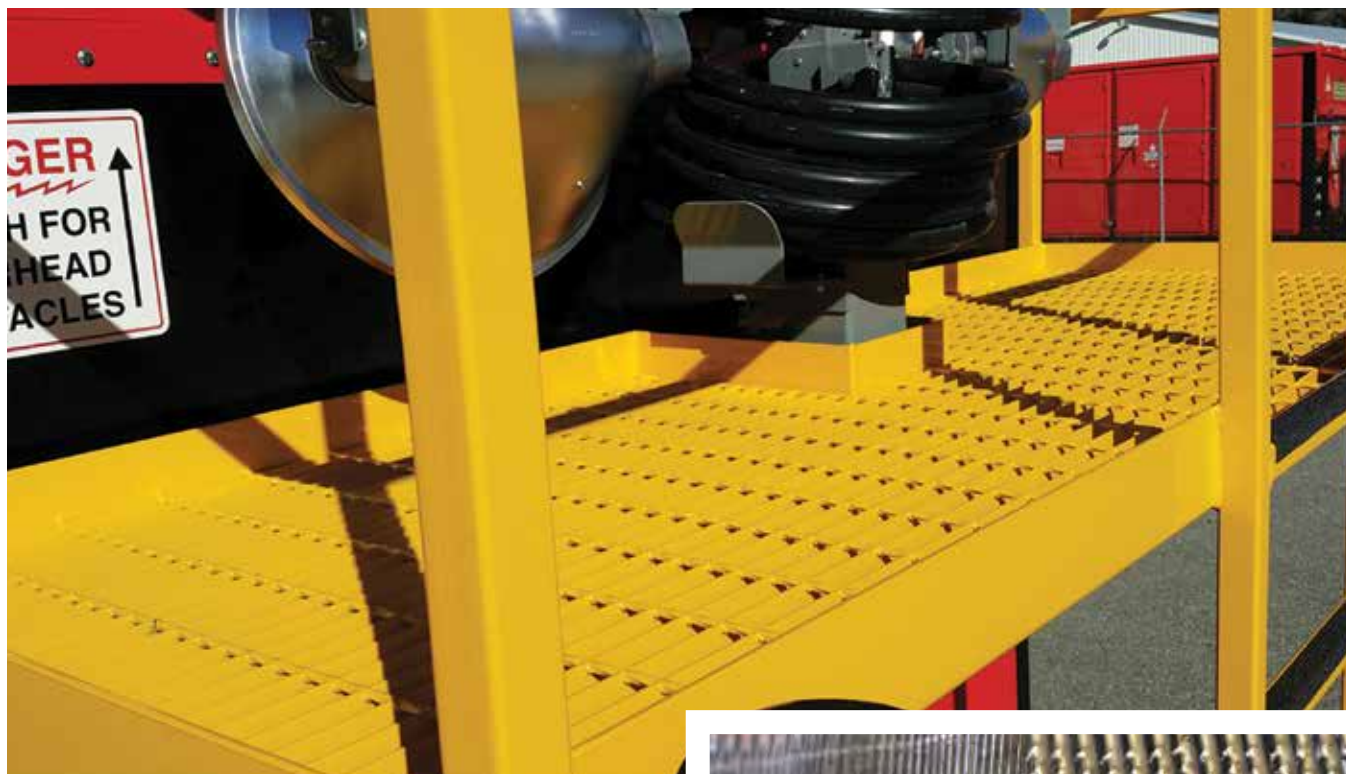

www accuratescreen.ca

PERFORATED

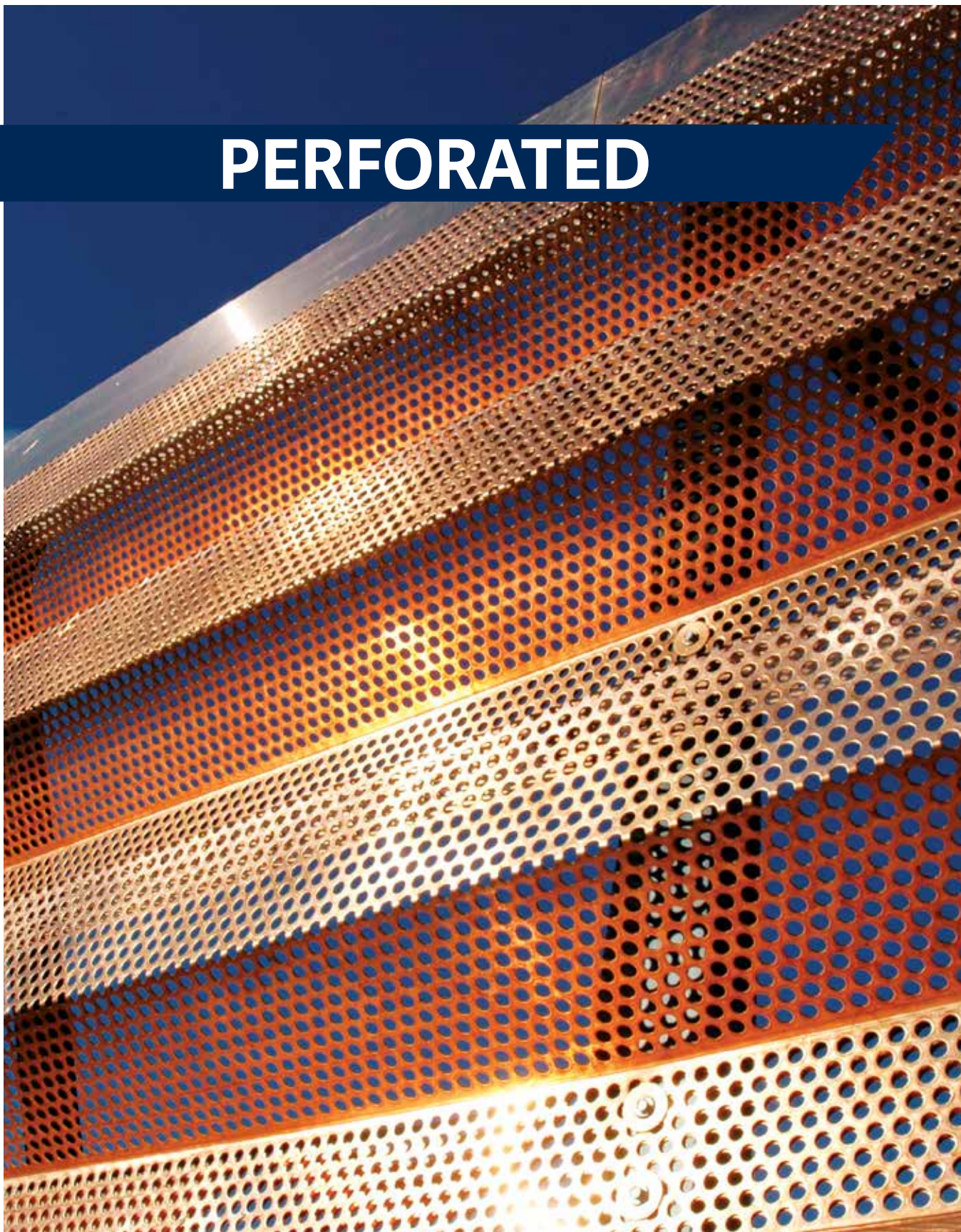

Fabrication

Perforated

Welded

Woven

Expanded

Bar Grating

Fibreglass

Channel Grating

ALU Deck & Clad
Non-Slip Floor

Wire, Banding
& Fasteners

Architectural

Available Perforated Metal Patterns

Round Staggered	Round Inline	Square Inline	Slotted	Decorative
-----------------	--------------	---------------	---------	------------

This is a random sampling of pattern size and open area drawings. For the complete selection of our Round Staggered Perforated Metal drawings go to the Perforated Metal page at www accuratescreen.ca

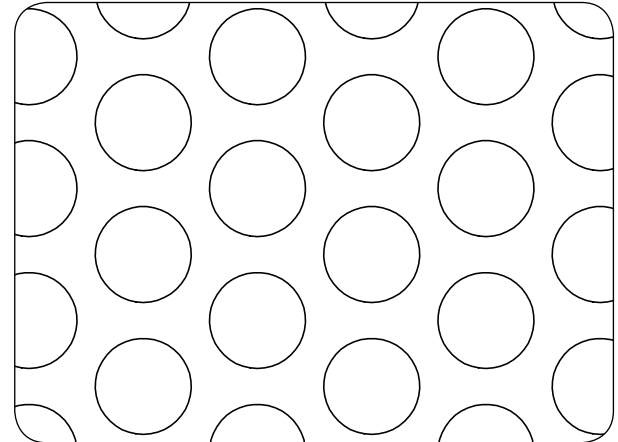
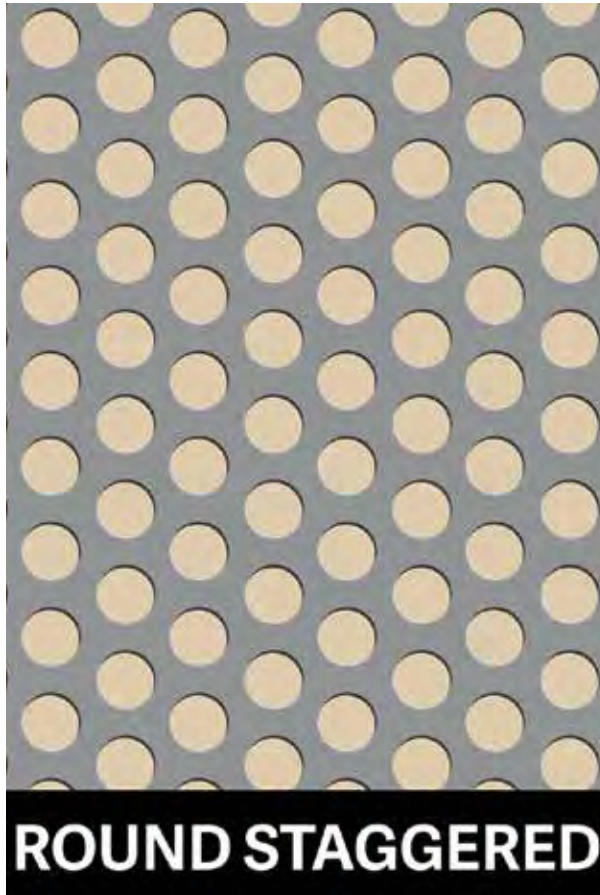

.500" dia., .687" Staggered Centres, 48% Open Area

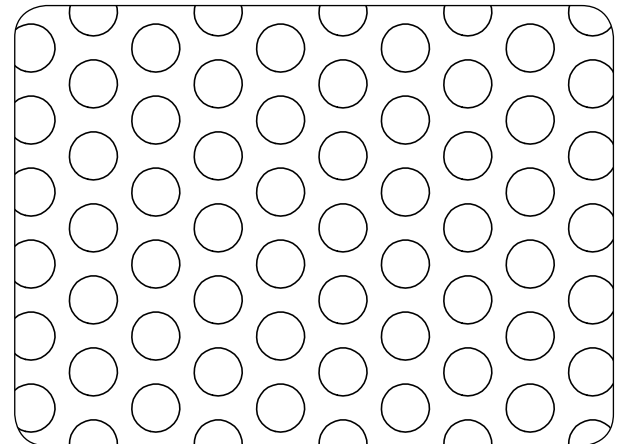

.250" dia., .375" Staggered Centres, 40% Open Area

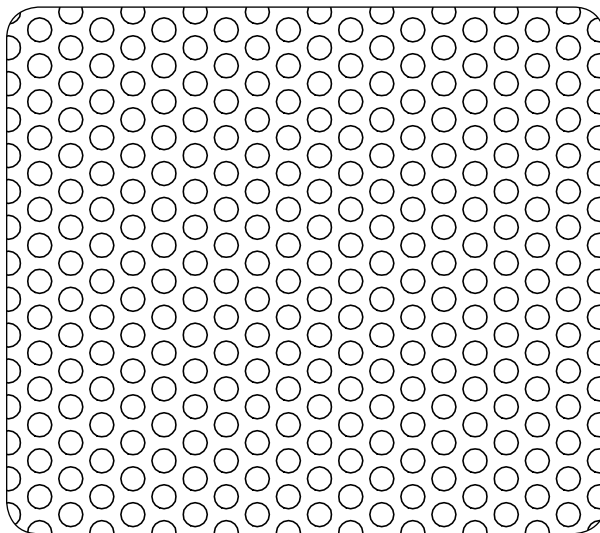

.125" dia., .187" Staggered Centres, 40% Open Area

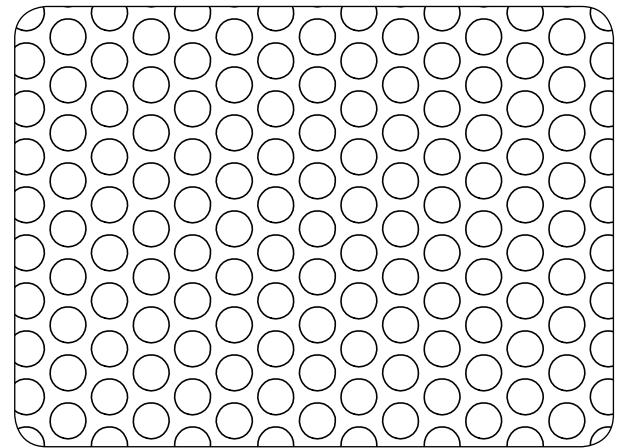

.187" dia., .250" Staggered Centres, 51% Open Area

Pattern Specifications - Round Staggered

The table below represents a portion of the Round Staggered Pattern configurations available. For our full listing go to www accuratescreen.ca or speak with your Accurate Screen Sales Representative.

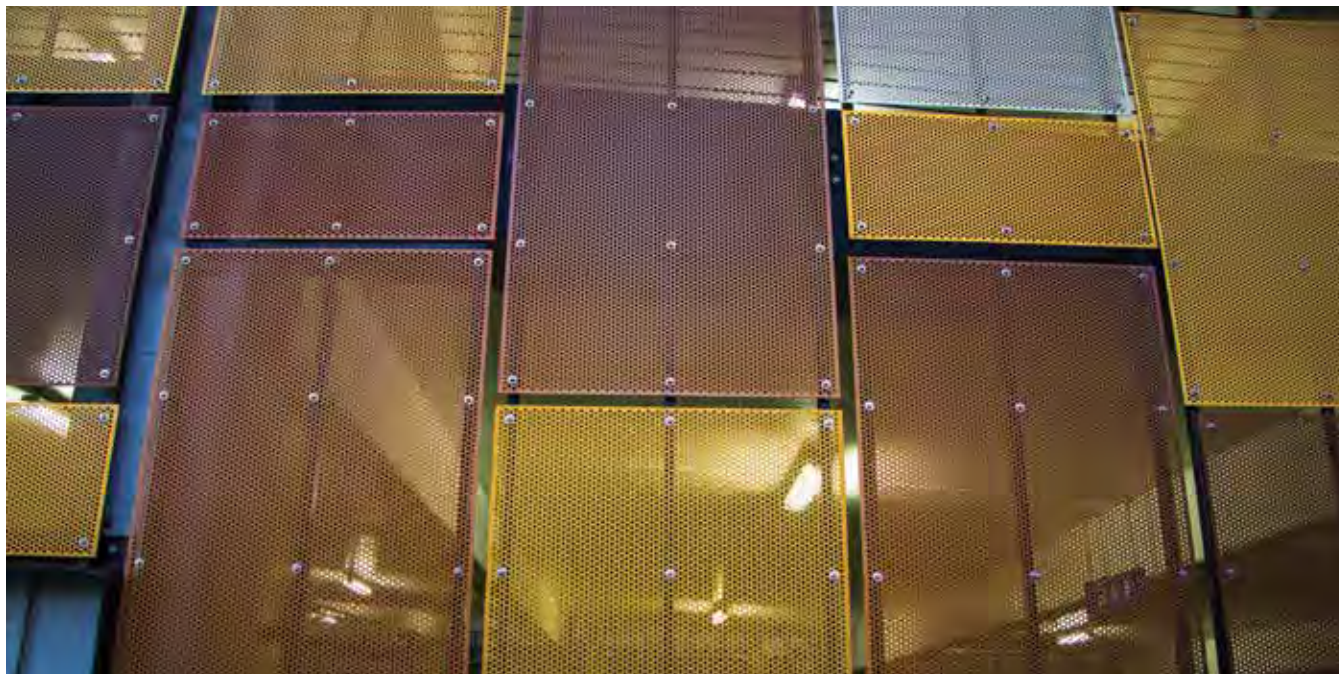

Round Staggered Pattern

Hole Diameter	Centre to Centre	% Open Area
1.000" (1")	1.250" (1-1/4")	58%
0.750" (3/4")	1.000" (1")	51%
0.500" (1/2")	0.687" (11/16")	48%
0.375" (3/8")	0.500" (1/2")	51%
0.250" (1/4")	0.375" (3/8")	40%
0.250" (1/4")	0.312" (5/16")	58%
0.187" (3/16")	0.312" (5/16")	33%
0.187" (3/16")	0.250" (1/4")	51%
0.156" (5/32")	0.218" (7/32")	46%
0.156" (5/32")	0.187" (3/16")	63%
0.125" (1/8")	0.375" (3/8")	10%
0.125" (1/8")	0.218" (7/32")	30%
0.125" (1/8")	0.187" (3/16")	40%
0.093" (3/32")	0.156" (5/32")	33%
0.062" (1/16")	0.125" (1/8")	23%
0.062" (1/16")	0.093" (3/32")	40%

- Available sheet size may vary. However, the majority of our Perforated Metal will be available in 4' x 8' or 4' x 10' sheets.
- Patterns are dependent on alloy and gauge combination.
- For sheet weight and open area calculations visit the Perforated Metal section of our website. www accuratescreen.ca

Available Perforated Metal Patterns

Round Staggered	Round Inline	Square Inline	Slotted	Decorative

This is a random sampling of pattern size and open area drawings. For the complete selection of our Round Inline Perforated Metal drawings go to the Perforated Metal page at www accuratescreen.ca

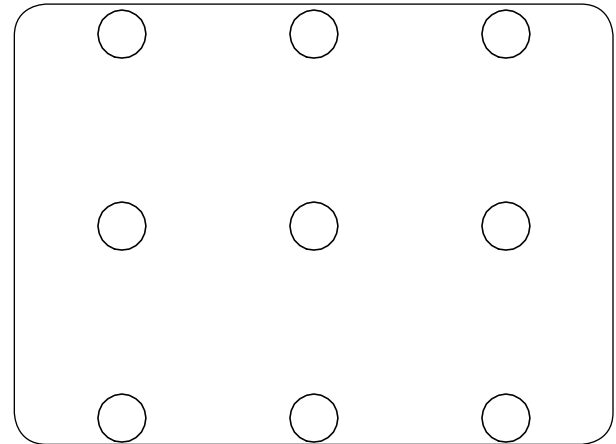

.250" dia., 1.00" Inline Centres, 5% Open Area

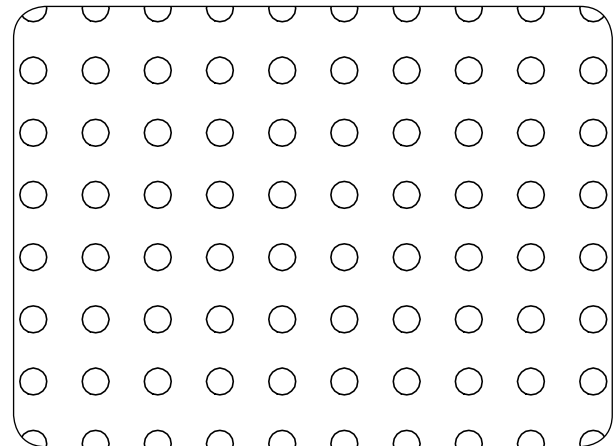

.140" dia., .324" Inline Centres, 15% Open Area

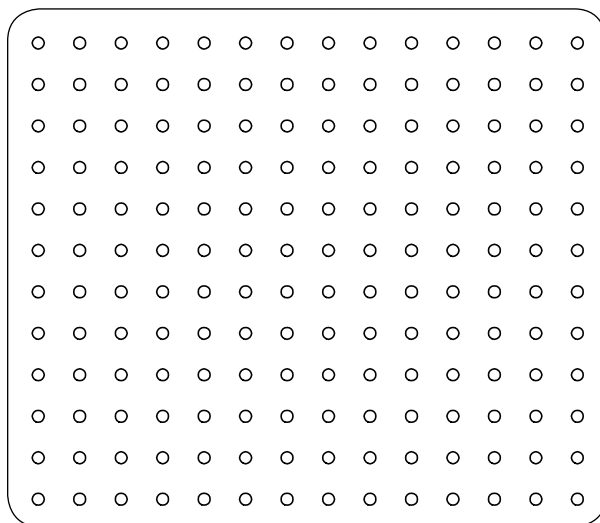

.062" dia., .216" Inline Centres, 6% Open Area

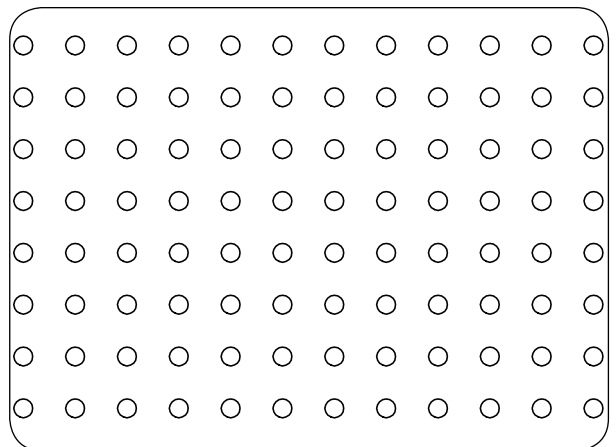

.098" dia., .270" Inline Centres, 10% Open Area

Available Perforated Metal Patterns

Round Staggered	Round Inline	Square Inline	Slotted	Decorative
-----------------	--------------	----------------------	---------	------------

This is a random sampling of pattern size and open area drawings. For the complete selection of our Square Inline Perforated Metal drawings go to the Perforated Metal page at www accuratescreen.ca

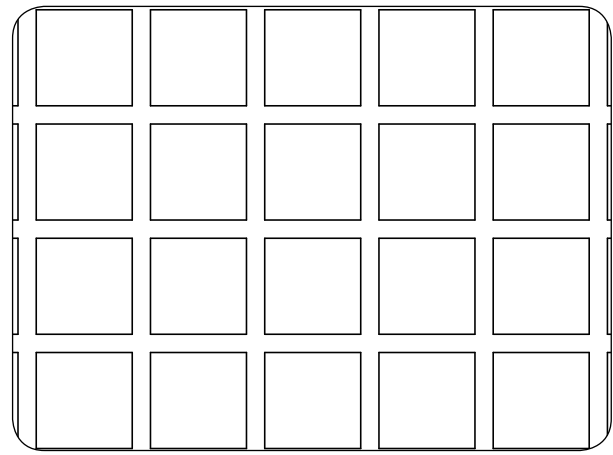
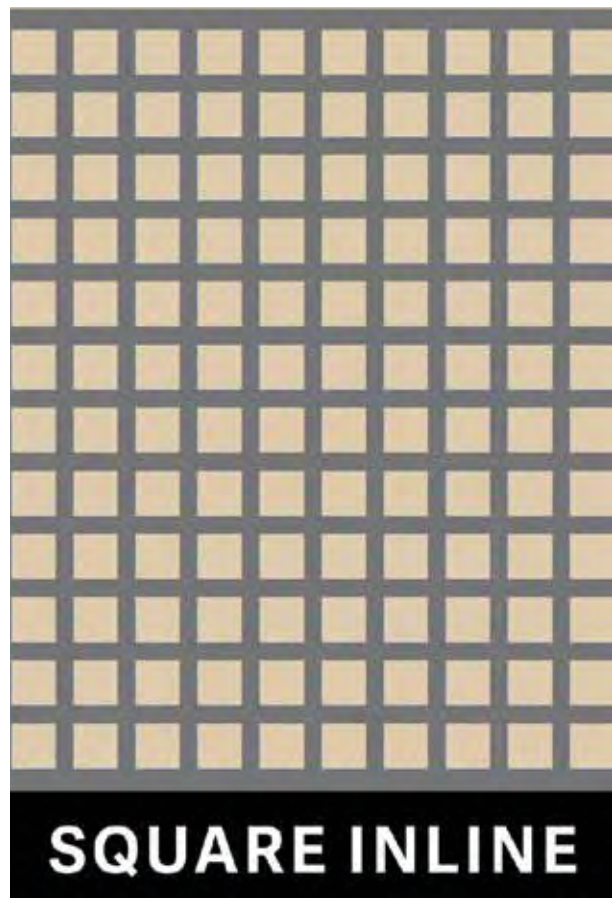

.500" sq., .595" Inline Centres, 70% Open Area

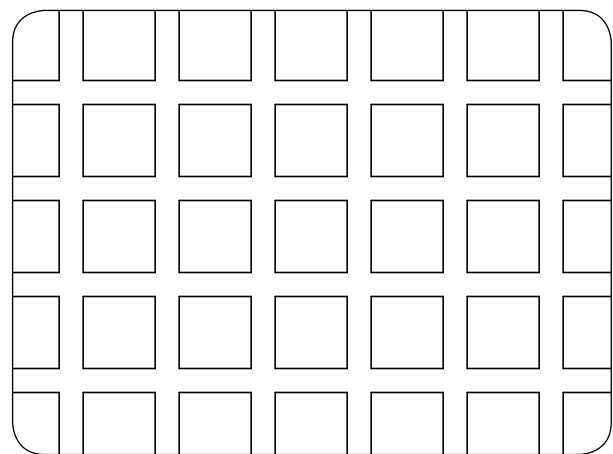

.375" sq., .500" Inline Centres, 56% Open Area

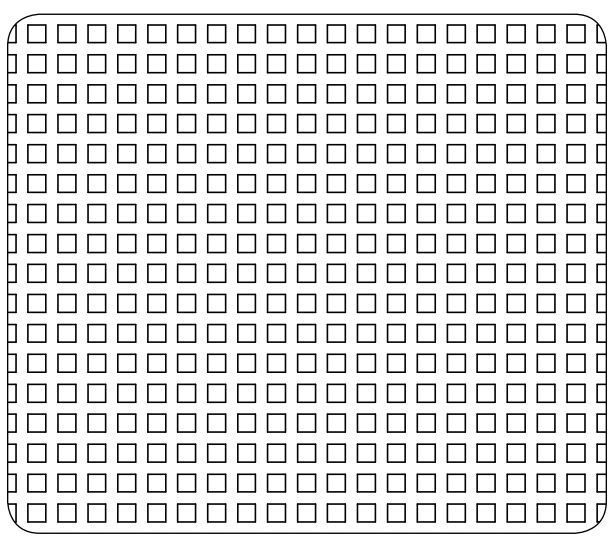

.093" sq., .156" Inline Centres, 36% Open Area

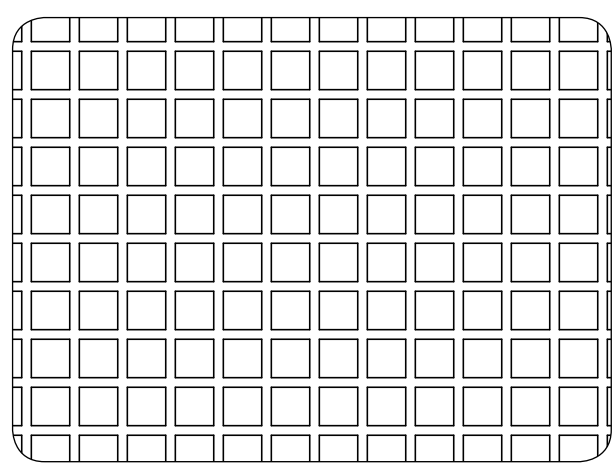

.200" sq., .250" Inline Centres, 58% Open Area

Available Perforated Metal Patterns

Round Staggered	Round Inline	Square Inline	Slotted	Decorative
-----------------	--------------	---------------	---------	------------

This is a random sampling of pattern size and open area drawings. For the complete selection of our Slotted Perforated Metal drawings go to the Perforated Metal page at www accuratescreen.ca

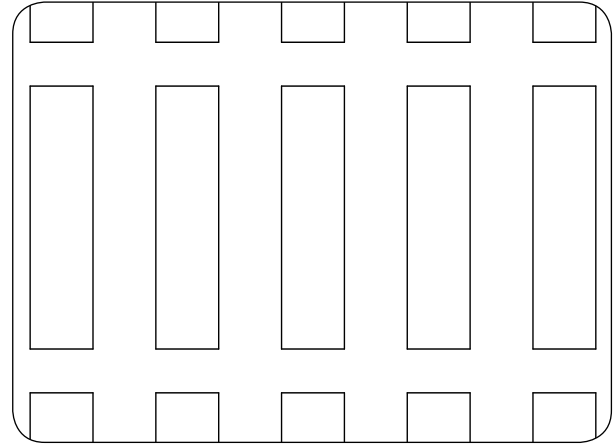

.375" x 1.50", .750" Inline Centres, 55% Open Area

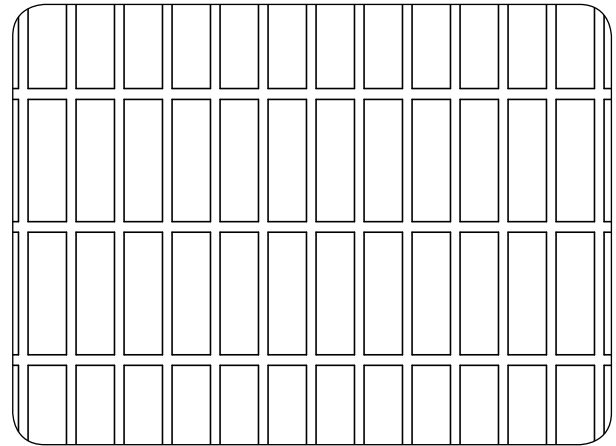

.200" x .637", .693" Inline Centres, 75% Open Area

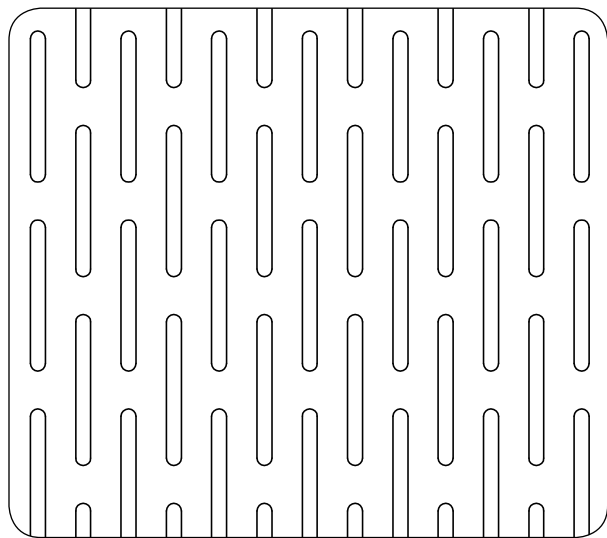

.078" x .787", .984" Stagger Centres 25% Open Area

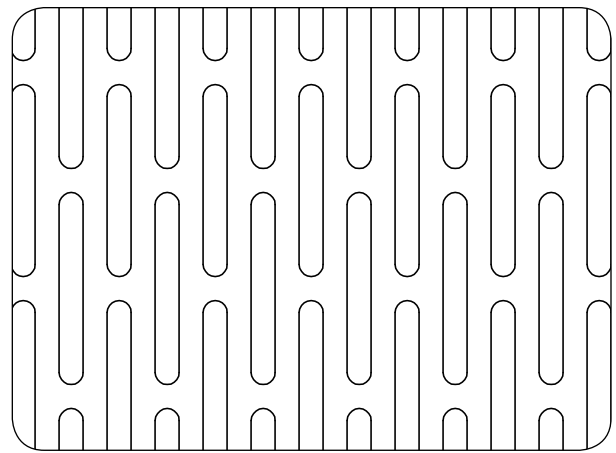

.125" x 1.00", 1.125" Stagger Centres, 43% Open Area

Available Perforated Metal Patterns

Round Staggered	Round Inline	Square Inline	Slotted	Decorative
-----------------	--------------	---------------	---------	------------

This is a random sampling of pattern size and open area drawings. For the complete selection of our Decorative Perforated Metal drawings go to the Perforated Metal page at www accuratescreen.ca

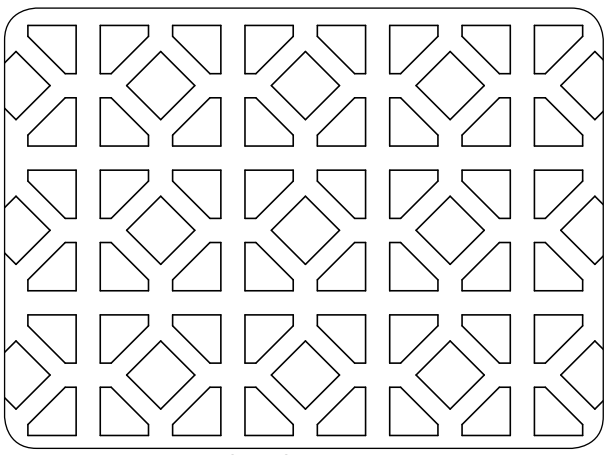

Tri-Square/Windsor, 45% Open Area

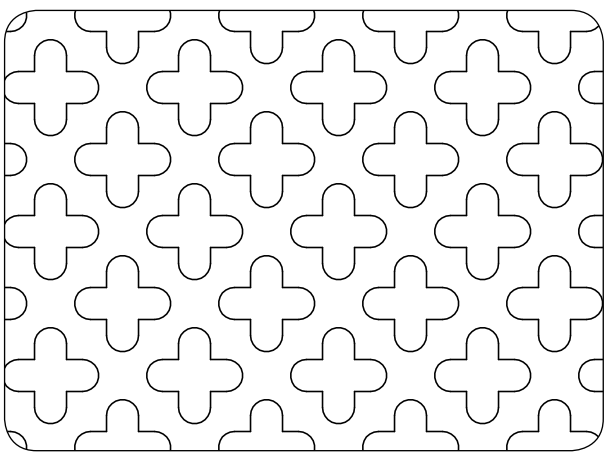

Clover, 51% Open Area

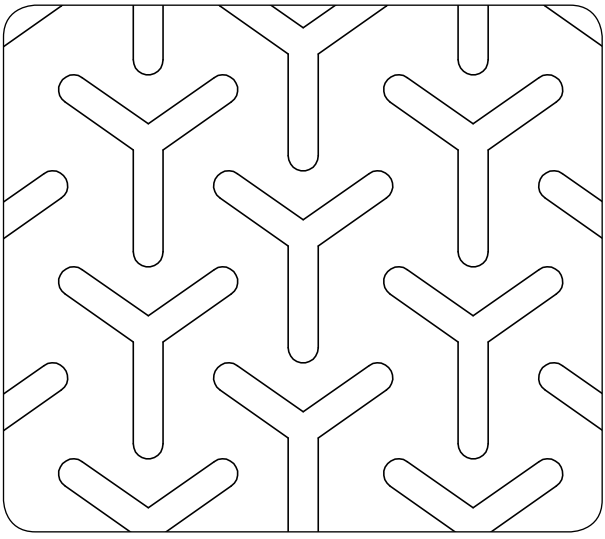

Y Slot, 30% Open Area

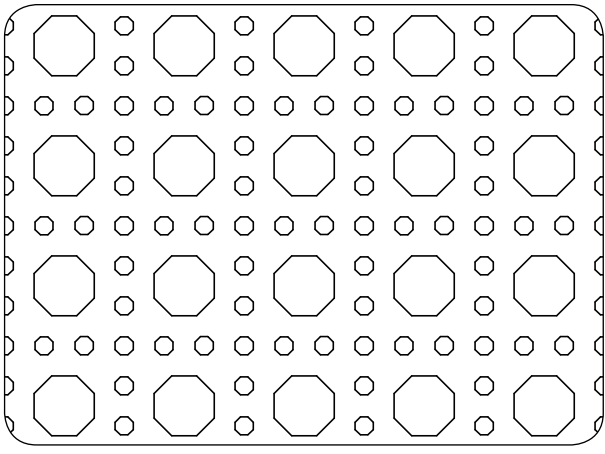

Octacane, 41% Open Area

Product Applications



Perforated Metal has many varied uses. As an industrial product it is an excellent material for noise reduction applications, and it is often used as an air control, filtration and screening material for the Oil and Gas industry. In the Agricultural sector it is used in seed and grain sorting.

The various alloys and patterns available in perforated metal make it a preferred material amongst architects and designers for construction applications such as facades, ceilings, shelves, and stair finishes.

An Accurate Screen Sales Representative can help you choose the right Perforated Metal for your next project.

www accuratescreen.ca

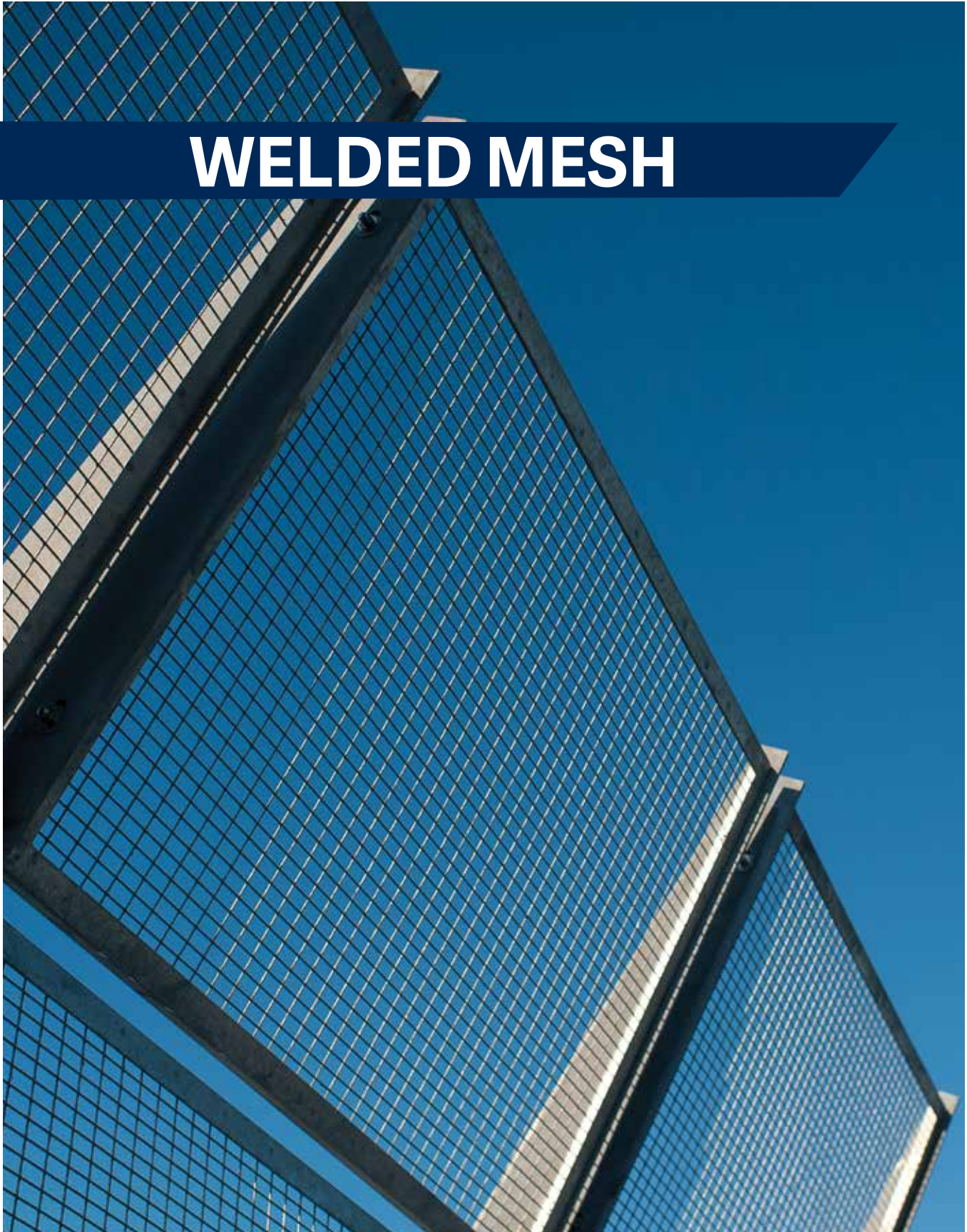

WELDED MESH

Fabrication

Perforated

Welded

Woven

Expanded

Bar Grating

Fibreglass

Channel Grating

ALU Deck & Clad
Non-Slip Floor

Wire, Banding
& Fasteners

Architectural

Dimension Specifications & Terminology

Accurate Screen and Grating stocks a wide assortment of Welded Mesh in various alloys, sheet sizes and roll sizes. Please call your Accurate Screen Sales Representative with your specific requirements. They will be able to assist you in determining the size of material available to meet your needs.

When discussing the purchase of Welded Mesh with your Accurate Screen Sales Representative it is important to supply them with the proper information so they can provide you an exact quote. To assist in specifying your requirements we have provided the following specification and terminology information.

Explanation of 'opening vs mesh' terminology:

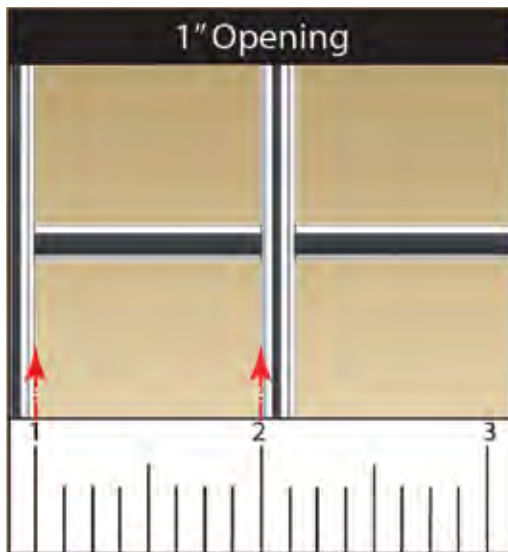

When the word 'opening' is used to describe the measurement of woven or welded wire it indicates the space measured inside-to-inside of wire.

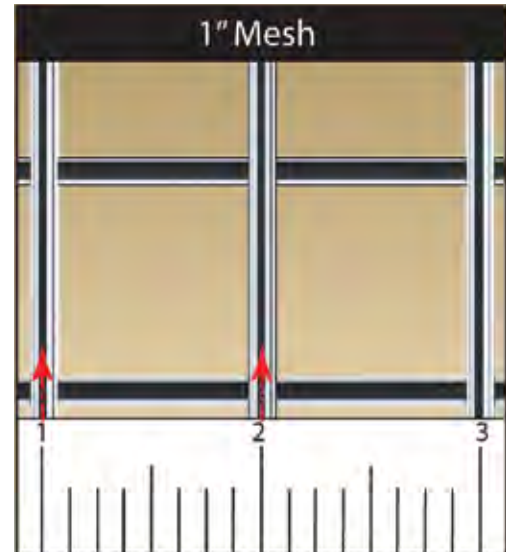

When the word 'mesh' is used to describe the measurement of woven or welded wire it indicates the space measured centre-to-centre of wire.

Edge Requirements:

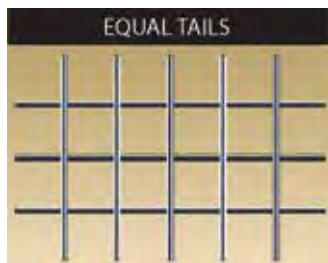

- Wire mesh fitting into a channel frame can have equal edges without extra work, or safety concerns.
- More time to weld into an angle frame than flush edges.



- Specific trim for application purposes.
- Requires less welds to attach it to a frame work.



- Less likely to get shipping damages and easier to handle with flush edges.
- Requires less welds to attach it to a frame work.



- Easiest (least expensive) to shear wire mesh with random tails.
- Less shears to get product to size.

Dimension Specifications & Terminology

This is the current selection of our Welded Mesh stock. For non-stock items contact your Accurate Screen Sales Representative. They will assist you in ordering the welded material you need for your project.

Welded Mesh			
Mesh	Wire Diameter	Opening	Lbs/Sq.Ft
ROLL STOCK			
2	.032"	0.47"	0.13
2	.035"	0.47"	0.16
2	.041"	0.46"	0.22
2	.047"	0.45"	0.28
2	.063"	0.44"	0.50
3	.047"	0.29"	0.43
4	.028"	0.22"	0.20
1/2" x 1"	0.063	0.44" x 0.94"	0.70
3/4"	.051"	0.70"	0.13
1"	.032"	0.97"	0.07
1"	.063"	0.94"	0.25
1"	.080"	0.92"	0.41
2"	.063"	1.94"	0.13
2"	.080"	1.92"	0.21
2"	.105"	1.90"	0.35
2"	.135"	1.87"	0.60
6"	.135"	5.87"	0.20
SHEET STOCK			
2	.063"	0.44"	0.55
7/8"	.125"	0.75"	1.18
1.0"	.125"	0.87"	1.25
1.0"	.187"	0.81"	2.25
1.0"	.250"	0.75"	4.59
1.25"	.125"	1.13"	0.78
1.50"	.125"	1.38"	0.75
1.50"	.187"	1.31"	1.41
2.00"	.125"	1.88"	0.51
2.00"	.135"	1.87"	0.62
2.00"	.148"	1.85"	0.75
2.00"	.187"	1.81"	1.13
2.00"	.250"	1.75"	2.03
2.00"	.375"	1.63"	4.22
3.00"	.125"	2.88"	0.32
3.00"	.187"	2.81"	0.85
3.00"	.250"	2.75"	1.41
3.00"	.375"	2.63"	3.02
4.00"	.135"	3.87"	0.28
4.00"	.187"	3.81"	0.62
4.00"	.225"	3.78"	0.83
4.00"	.250"	3.75"	1.02
4.00"	.375"	3.63"	2.12
2.00" x 1.00"	.125"	1.88" x 0.88"	0.84
4.00" x 2.00"	.125"	3.88" x 1.88"	0.42
4.00" x 2.00"	.250"	3.75" x 1.75"	1.54
6.00"	.135"	5.87"	0.21
6.00"	.148"	5.85"	0.24
6.00"	.187"	5.81"	0.38
6.00"	.250"	5.75"	0.68

Dimension Specifications & Terminology



Hardware Cloth / Galvanized Wire Cloth

Mesh	Wire Diameter	Opening	Lbs/Sq.Ft
1	0.080"	0.920"	0.41
1	0.063"	0.937"	0.26
1	0.054"	0.946"	0.23
3/4	0.051"	0.699"	0.13
2	0.063"	0.437"	0.51
2	0.054"	0.446"	0.46
2	0.041"	0.459"	0.22
2	0.035"	0.465"	0.20
4	0.025"	0.225"	0.16
4	0.023"	0.231"	0.14
8	0.017"	0.108"	0.16
8	0.014"	0.111"	0.11

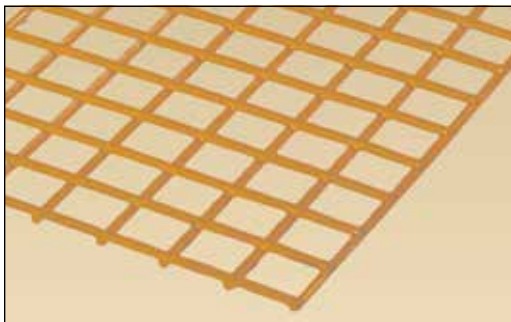

PVC Coated Welded Mesh

Mesh	Pre/Post Wire Diameter	Opening	Lbs/Sq.Ft
SHEET STOCK			
2	.063"/.095"	0.40"	0.53
1"	.105"/.140"	0.86"	0.81
ROLL STOCK			
2	.063"/.095"	0.40"	0.53
1"	.105"/.140"	0.86"	0.81
2-1/8"	.105"/.140"	2.00"	0.38

Customized Welded Mesh

Provide us with your specifications on the Welded Wire Mesh you require and we will provide an estimated cost and completion time for your approval prior to proceeding.

At Accurate we use a range of manufacturing equipment to efficiently produce small and large orders. From stock to customized pieces we can fulfill your mesh requirements

When planning your custom Wire Mesh requirements all of the following items should be presented with your drawings. This will ensure we provide you with an accurate estimate.

1. Size of Opening
2. Wire Diameter
3. Alloy
4. Piece Size
5. Quantity of Pieces to fabricate
6. Edge Requirements

We have provided calculation tools for you to determine sheet weights, openings and mesh counts. Go to the 'Calculations and Conversions' page on our website , www accuratescreen.ca, for wire mesh calculators.

WOVEN MESH



Fabrication

Perforated

Welded

Woven

Expanded

Bar Grating

Fibreglass

Channel Grating

ALU Deck & Clad
Non-Slip Floor

Wire, Banding
& Fasteners

Architectural

Woven Mesh Count Samples & Weave Styles

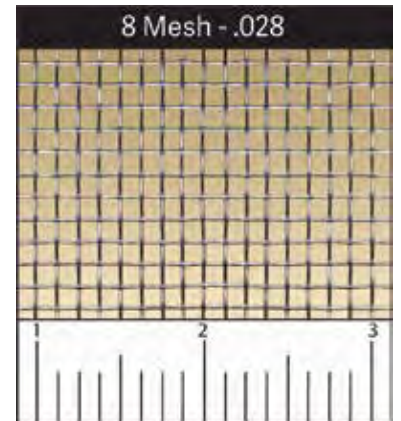
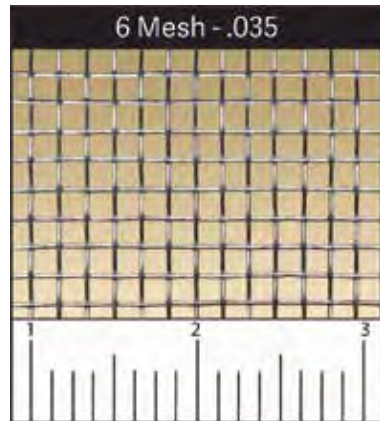
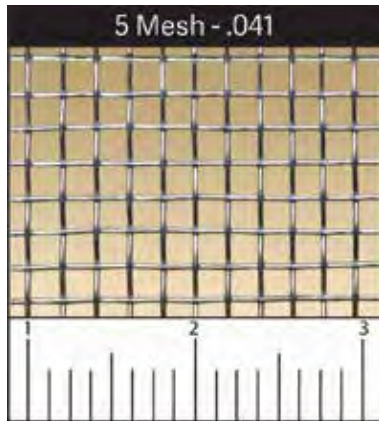
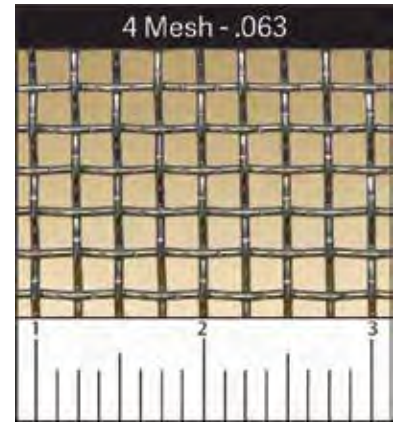
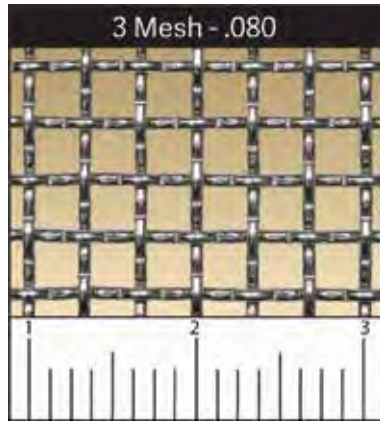
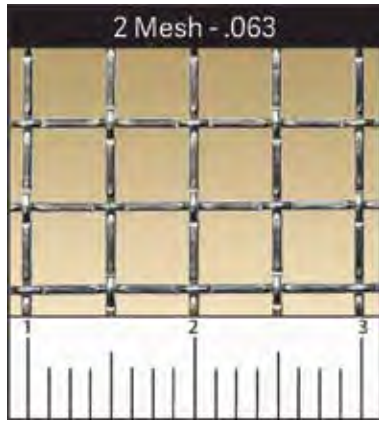

Woven Mesh Alloys and Dimensions

Explanation of Mesh Count Terminology:

- Example: 4" Open = a 4" opening, measured from inside wire edge to inside wire edge.
- Example: 2" Mesh = a 2" measurement from centre to centre of wire.
- Example: 8 Mesh = a total of 8 equal openings within a 1" measurement, from center to center of wire.

STEEL WOVEN MESH

Mesh	Wire Diameter	Opening	Lbs/Sq.Ft
4.500"	0.500"	4.00"	3.580
4.375"	0.375"	4.00"	2.060
3.500"	0.500"	3.00"	5.100
2.375"	0.375"	2.00"	4.600
2.00"	0.312"	1.6875"	3.200
2.00"	0.250"	1.750"	2.030
2.00"	0.187"	1.8125"	1.220
1.8125"	0.312"	1.500"	3.840
1.625"	0.135"	1.500"	0.750
1.250"	0.250"	1.00"	3.250
1.00"	0.135"	0.875"	1.180
0.968"	0.207"	0.750"	3.150
0.875"	0.125"	0.750"	1.300
0.750"	0.125"	0.625"	1.600
0.687"	0.177"	0.500"	3.280
0.625"	0.125"	0.500"	1.510
0.500"	0.135"	0.375"	2.000
0.375"	0.125"	0.250"	2.960
2	0.063"	0.437"	0.510
3	0.080"	0.253"	1.260
4	0.047"	0.203"	0.510
4	0.063"	0.187"	1.050
6	0.035"	0.132"	0.480
8	0.020"	0.105"	0.208
8	0.023"	0.102"	0.275
8	0.028"	0.097"	0.410
8	0.032"	0.093"	0.550
10	0.025"	0.075"	0.410
14	0.020"	0.052"	0.380
20	0.016"	0.034"	0.070

STAINLESS STEEL WOVEN MESH (cont'd next page)

Mesh	Wire Diameter	Opening	Micron	% Open	Lbs/Sq.Ft
2.00"	0.25	1.75"	-	82	2.03
1.1875"	0.187	1.00"	-	61	2.18
1.00"	0.135"	.865"	-	75	1.19
0.875"	0.125	.625"	-	80	1.18
0.625"	0.125"	.500"	-	85	1.67
0.500"	0.125	.375"	-	88	2.10
0.375"	.125"	.250"	-	91	2.97
2	0.047"	.453"	-	82	0.29
2	0.063"	.437"	-	76	0.52
2	0.080"	.420"	-	71	0.84
2	0.105"	.395"	-	62	1.46

Woven Mesh Alloys and Dimensions

STAINLESS STEEL WOVEN MESH (cont'd next page)

Mesh	Wire Diameter	Opening	Micron	% Open	Lbs/Sq.Ft
2	0.135"	0.365"	-	53	2.44
3	0.047"	0.286"	-	74	0.43
3	0.063"	0.270"	-	66	0.78
3	0.080"	0.253"	-	58	1.27
4	0.028"	0.222"	-	79	0.20
4	0.035"	0.215"	-	74	0.28
4	0.047"	0.203"	-	66	0.51
4	0.063"	3/16"	-	56	0.92
4	0.080"	0.170"	-	46	1.50
5	0.032"	0.168"	-	71	0.34
5	0.041"	0.159"	-	63	0.55
6	0.028"	0.139"	-	69	0.31
6	0.035"	0.132"	-	62	0.49
6	0.047"	0.119"	-	51	0.89
6	0.063"	0.104"	-	39	1.65
8	0.025"	0.100"	-	64	0.33
8	0.028"	0.097"	-	60	0.42
8	0.032"	0.093"	-	55	0.55
8	0.035"	0.090"	-	52	0.55
8	0.047"	0.078"	-	39	1.22
8	0.063"	0.062"	-	25	2.18
10	0.020"	0.080"	-	64	0.26
10	0.025"	0.075"	-	56	0.42
10	0.032"	0.068"	-	46	0.70
10	0.035"	0.065"	-	42	0.84
10	0.047"	0.053"	-	28	1.50
11	0.018"	0.073"	-	64	0.26
12	0.018"	0.065"	-	61	0.26
12	0.023"	0.060"	-	52	0.43
12	0.028"	0.055"	-	44	0.64
12	0.032	0.051"	-	38	0.97
12	0.035"	0.048"	-	34	1.03
14	0.009"	0.062"	-	76	0.08
14	0.020"	0.051"	-	52	0.38
16	0.009"	0.054"	-	73	0.09
16	0.016"	0.047"	-	55	0.27
16	0.018"	0.045"	-	51	0.35
16	0.023"	0.040"	-	40	0.54
16	0.028"	0.035"	-	31	0.84
18 x 16	0.011"	Insect Cloth	-	73	0.03
18	0.009"	0.047"	-	70	0.10
18	0.012"	0.044"	-	62	0.17
18	0.015"	0.041"	-	53	0.27
18	0.017"	0.039"	-	48	0.35
20	0.009"	0.041"	1041	67	0.11
20	0.014"	0.036"	914	52	0.26
20	0.016"	0.034"	864	46	0.35
20	0.020"	0.030"	762	36	0.56
24	0.0075"	0.034"	868	67	0.09

Woven Mesh Alloys and Dimensions

STAINLESS STEEL WOVEN MESH

Mesh	Wire Diameter	Opening	Micron	% Open	Lbs/Sq.Ft
24	0.015"	0.027"	676	41	0.16
28	0.010"	0.026"	653	52	0.25
30	0.0065"	0.027"	676	65	0.09
30	0.0085"	0.025"	630	55	0.14
30	0.0095"	0.024"	605	51	0.18
30	0.011"	0.022"	566	45	0.25
30	0.012"	0.021"	549	41	0.30
35	0.011"	0.018"	457	38	0.29
38	0.0046"	0.0217"	551	68	0.06
38	0.0065"	0.0198"	503	57	0.11
40	0.0065"	0.0185"	470	55	0.11
40	0.0085"	0.0165"	419	44	0.20
40	0.0095"	0.0155"	394	38	0.25
40	0.010"	0.0150"	381	36	0.28
50	0.0039"	0.0161"	409	65	0.07
50	0.0045"	0.0155"	394	60	0.07
50	0.0055"	0.0145"	368	53	0.10
50	0.0085"	0.0115"	292	33	0.24
50	0.0090"	0.011"	279	30	0.27
60	0.0040"	0.0127"	323	58	0.07
60	0.0045"	0.0122"	310	53	0.08
60	0.0065"	0.0102"	259	38	0.18
60	0.0075"	0.0092"	234	31	0.24
70	0.003"	0.0113"	287	62	0.07
70	0.0037"	0.0106"	269	55	0.07
70	0.0065"	0.0078"	198	30	0.21
80	0.0037"	0.0088"	224	50	0.07
80	0.0055"	0.0070"	178	31	0.17
84	0.0025"	0.0094"	239	62	0.06
100	0.0022"	0.0078"	198	61	0.03
100	0.0045"	0.0055"	140	30	0.14
120	0.0026"	0.0057"	145	47	0.05
120	0.0036"	0.0047"	119	32	0.09
130	0.0017"	0.0060"	152	61	0.05
150	0.0026"	0.0041"	104	38	0.07
160	0.0014"	0.0048"	123	60	0.04
180	0.0012"	0.0043"	111	62	0.04
180	0.0023"	0.0033"	84	35	0.07
200	0.0016"	0.0034"	86	46	0.04
200	0.0021"	0.0029"	74	34	0.06
220	0.0011"	0.0034"	88	58	0.04
250	0.0011"	0.0029"	74	53	0.04
250	0.0016"	0.0024"	61	36	0.05
270	0.0014"	0.0023"	58	39	0.04
270	0.0016"	0.0021"	33	32	0.05
325	0.0014"	0.0017"	43	30	0.04
400	0.0012"	0.0013"	33	27	0.04
500	0.0010"	0.0010"	25	25	0.04
625	0.0008"	0.0008"	20	25	0.03

Woven Mesh Alloys and Dimensions

ALUMINUM WOVEN MESH

Mesh	Wire Diameter	Opening	Weight lbs/sf
2.00"	0.250"	1.75"	0.69
2.00"	0.188"	1.8125"	0.39
1.250"	0.250"	1.00"	1.38
1.1875"	0.192"	1.00"	0.69
0.875"	0.125"	1.00"	0.34
0.625"	0.125"	0.50"	0.53
2	0.063"	0.4375"	0.17
8	0.028"	0.097"	0.10
18 x 16	0.011"	.051 x .044"	0.03

- Aluminum Mesh standard sheet size is 4' x 8'
- Stainless Steel available in 304 and 316 grade.
- Roll width standards are 36", 48", 60" and 72"
- For mesh screen formulas such as opening and sheet weight please visit calculations on our web site - www accuratescreen.ca
- Non-stock sizes, alloys and mesh types are subject to availability.

HIGH CARBON STEEL

Opening	Wire Diameter	Lbs/Sq.Ft.
4.00"	.500"	3.58
3.00"	.500"	4.62
2.50"	.437"	4.22
2.25"	.375"	3.46
2.00"	.375"	3.84
1.75"	.375"	4.30
1.50"	.312"	3.50
1.25"	.312"	4.08
1.125"	.250"	2.96
1.0625"	.250"	3.11
1.00"	.250"	3.26
0.9375"	.225"	2.85
0.875"	.225"	3.01
0.75"	.207"	2.93
0.6875"	.192"	2.74
0.625"	.192"	2.97
0.5625"	.177"	2.81
0.50"	.177"	3.06
0.4375"	.162"	2.90
0.375"	.148"	2.79
0.3125"	.135"	2.72
0.250"	.120"	2.62
0.1875"	.092"	2.04
0.125"	.080"	2.15
0.0625"	.207"	2.76
0.125 x 3.00"	.080"	1.19
0.187" x 3.00"	.092"	1.20
0.250 x 3.00"	.120"	1.59
0.3125 x 4.00"	.135"	1.64
0.375 x 4.00"	.148"	1.74
0.50 x 5.00"	.177"	1.92

- All aggregate supplied in abrasive resistant high carbon steel.
- Supplied in Trommel, roll stock, hooked and flats
- Quick turnaround times due to extensive inventory.
- Custom specifications upon request.

Woven Mesh Alloys and Dimensions

Micronic Grade

Filter Fabric

Filter fabrics are used to trap unusual shape and size particles. The weave process forms a restrictive path that does not allow products to go straight through.

PLAIN DUTCH WEAVE

Mesh Count per Inch	Mesh Diameter Inches	Absolute Filter Rating Inches
24x110	.014" / .010"	115-125
30x150	.009" / .007"	95-100
30X250	.010" / .008"	90-100
40x200	.007" / .0055"	70-75
50x250	.0055" / .0045"	58-63

TWILL DUTCH WEAVE

Mesh Count per Inch	Mesh Diameter Inches	Absolute Filter Rating Inches
80x400	.0047" / .0030"	40-45
80x700	.0040" / .0030"	35-38
120x400	.0040" / .0023"	50-55
120x600	.0040" / .0023"	40-45
165x800	.0028" / .0020"	24-26
165x1400	.0028" / .0016"	16-18
200x600	.0024" / .0018"	28-32
200-1400	.0028" / .0016"	12-14
325x2300	.0015" / .0010"	8-9
510x3600	.0010" / .0006"	5-6

REVERSE PLAIN DUTCH WEAVE

Mesh Count per Inch	Mesh Diameter Inches	Absolute Filter Rating Inches
140 x 40	.0075 x .0150	110-125
130 x 35	.0079 x .0157	95-105
175 x 50	.0057 x .0120	65-72
*400 x 125	.0026 x .0039	56-62
280 x 70	.0035 x .0083	54-60
600 x 100	.0017 x .0055	35-38
600 x 125	.0017 x .0049	23-26
720 x 150	.0014 x .0043	18-21
850 x 155	.0012 x .0039	14-17

*TWILLED WEAVE

Wire Cloth

Comparison Chart

Filtration Micron Rating	Twill Dutch Weave	Plain Dutch Weave	Reverse Plain Dutch Weave	Square Weave
5 -	510 x 3600 MESH			
6 -	450 x 2750 MESH			
7 -				
8 -	325 x 2300 MESH			
9 -				
10 -	250 x 1400 MESH			
12 -	200 x 1400 MESH			
14 -			850 x 155 MESH	795 MESH
16 -	165 x 1400 MESH			
18 -			720 x 150 MESH	
20 -				635 MESH
25 -	165 x 800 MESH		600 x 125 MESH	510 MESH
30 -	200 x 600 MESH			450 MESH
35 -				
40 -	80 x 700 MESH		600 x 100 MESH	400 MESH
45 -	120 x 600 MESH	80 x 400 MESH		325 MESH
50 -				
55 -	120 x 400 MESH			270 MESH
60 -		50 x 250 MESH	280 x 70 MESH 400 x 125 MESH	
65 -				250 MESH
70 -			175 x 50 MESH	
75 -	40 x 560 MESH	40 x 200 MESH		
80 -				200 MESH
85 -				
90 -				
95 -	30 x 360 MESH			
100 -		30 x 150 MESH	130 x 35 MESH	
110 -				150 MESH
120 -	20 x 250 MESH			120 MESH
125 -		24 x 110 MESH	140 x 40 MESH	

- Material available in 304 and 316 grade Stainless Steel
- Non-stock sizes, alloys and mesh types are subject to availability

Expanded Metal

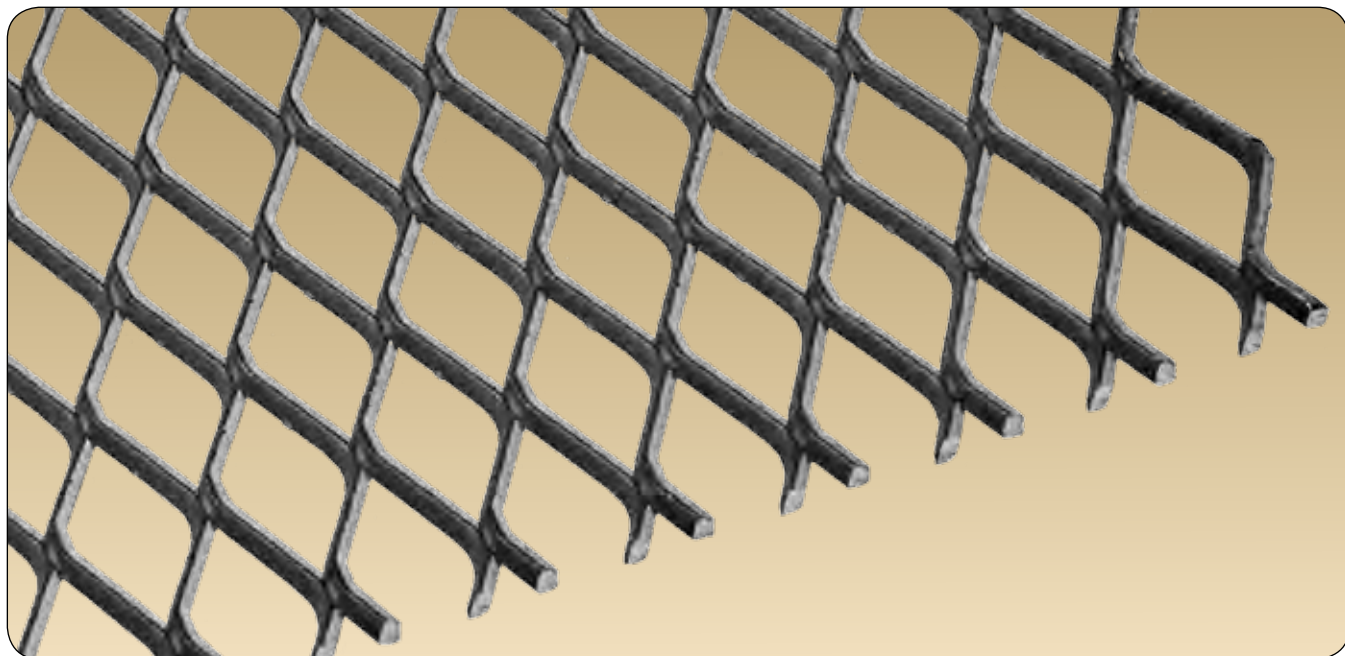

Raised expanded metal, also referred to as standard expanded metal, is the format of steel, aluminum or stainless steel after it has been put through the expanding press. The shearing and stretching of the expanding process creates strands and bonds that are set at a uniform angle to the plane on the sheet. This adds strength and rigidity to the material, while providing a directional skid-resistant surface.

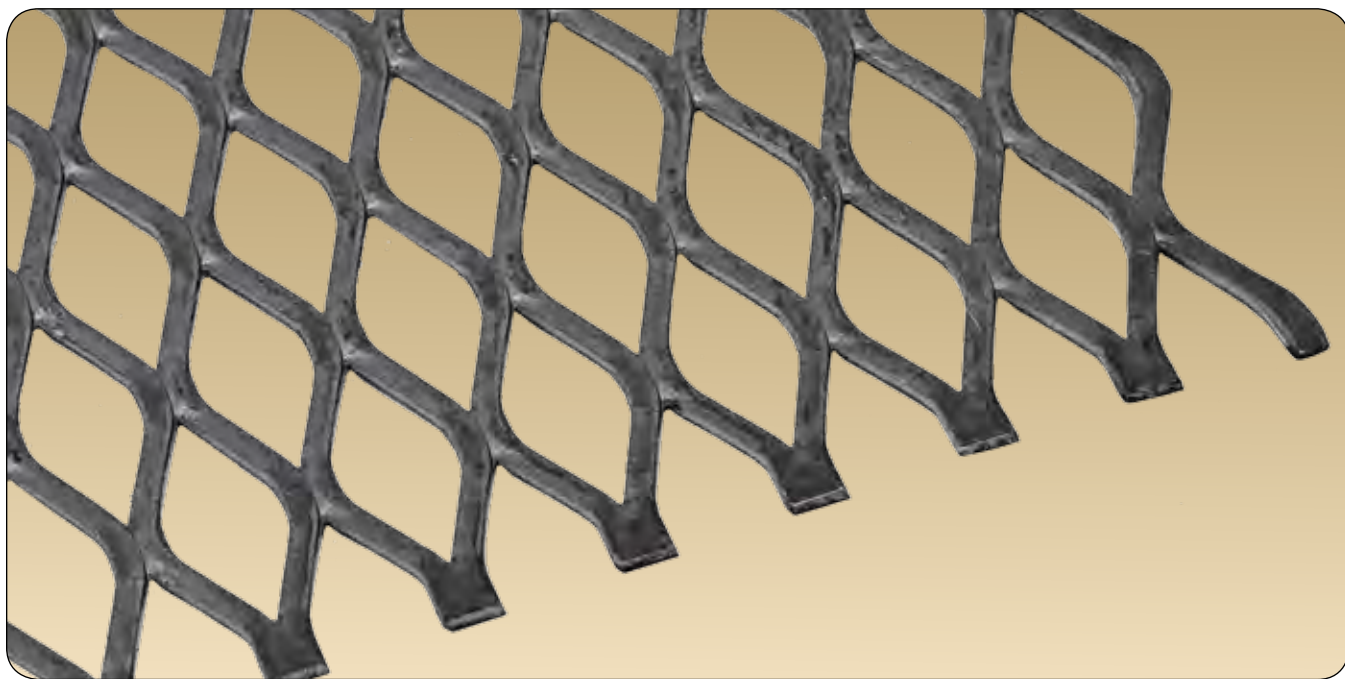

Flattened expanded metal is manufactured by passing the raised expanded sheet through a cold roll reducing mill. Flattened expanded metal turns the strands and bonds down to provide a flattened surface, reducing the thickness (gauge) and elongating the pattern.

EXPANDED METAL

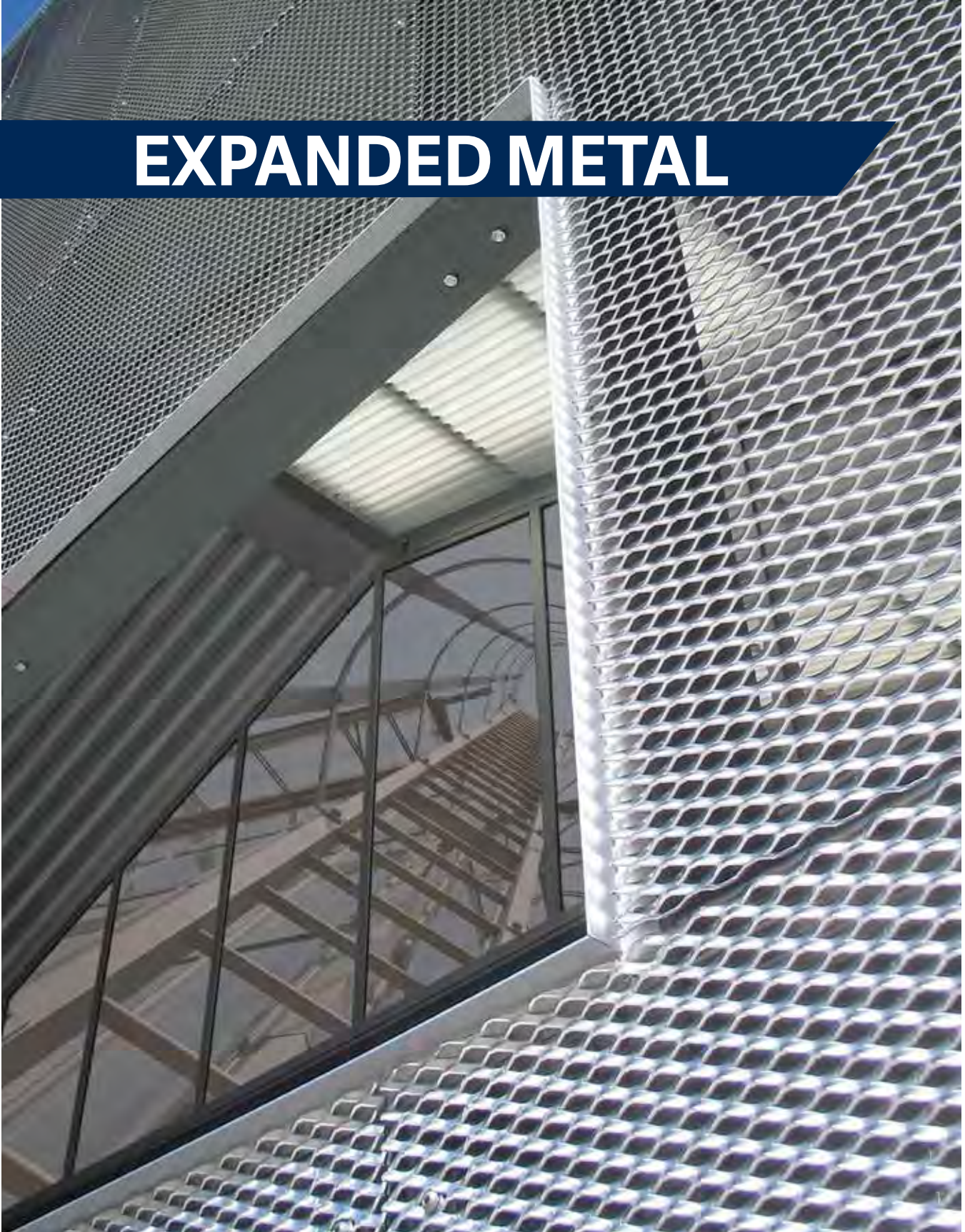

Fabrication

Perforated

Welded

Woven

Expanded

Bar Grating

Fibreglass

Channel Grating

ALU. Deck & Clad
Non-Slip Floor

Wire, Banding
& Fasteners

Architectural

Expanded Metal - Flat. Weights and Dimensions

CARBON STEEL – FLAT							
STYLE	LBS. PER 4 X 8 SHEET		DESIGN SIZE (IN.)		STRAND WIDTH (IN.)	OVERALL THICKNESS (IN.)	% OPEN AREA
	PLAIN	GALV. WT.	SWD	LWD	WIDTH		
3/16" #22	20	N/R	0.23	0.50	0.058	0.027	49
3/16" #20	26	N/R	0.23	0.50	0.063	0.032	44
1/4" #20	28	N/R	0.25	1.05	0.079	0.030	35
1/4" #18	34	N/R	0.25	1.05	0.080	0.040	35
5/16" #20	17	N/R	0.33	1.03	0.075	0.032	60
5/16" #18	30	N/R	0.33	1.03	0.099	0.040	45
1/2" #20	13	16	0.50	1.25	0.079	0.029	65
1/2" #18	21	26	0.50	1.25	0.097	0.039	60
1/2" #16	26	31	0.50	1.25	0.096	0.050	63
1/2" #13	45	52	0.50	1.25	0.107	0.070	52
3/4" #16	5	6	0.92	2.10	0.111	0.048	74
3/4" #14	20	25	0.92	2.10	0.105	0.061	74
3/4" #13	24	28	0.92	2.10	0.106	0.070	74
3/4" #10 (13ga)	36	41	0.92	2.10	0.160	0.070	68
3/4" #9 (10ga)	55	60	0.92	2.10	0.165	0.120	63
1" #16	13	16	1.00	2.50	0.098	0.050	78
1" #14	20	23	1.00	2.30	0.125	0.070	80
1" #12	31	36	1.00	2.30	0.156	0.085	74
1" #10	53	57	1.00	2.30	0.160	0.110	58
1 1/2" #12	21	24	1.41	3.20	0.116	0.085	85
1 1/2" #10	53	57	1.33	3.20	0.188	0.110	63
1-1/2" #16	12	15	1.33	3.20	0.119	0.048	83
1-1/2" #13	18	21	1.33	3.20	0.116	0.070	80
1-1/2" #9	37	40	1.33	3.20	0.158	0.110	75
1-1/2" #13	18	21	1.33	3.20	0.116	0.07	80
1-1/2" #9	36	40	1.33	3.20	0.158	0.11	75
STAINLESS STEEL – FLAT							
STYLE	LBS. PER 4 X 8 SHEET		DESIGN SIZE (IN.)		STRAND WIDTH (IN.)	OVERALL THICKNESS (IN.)	% OPEN AREA
	PLAIN		SWD	LWD	WIDTH		
1/4" #18	30		0.32	1.25	0.082	0.043	48
1/2" #20	15		0.50	1.25	0.091	0.033	60
1/2" #18	22		0.50	1.26	0.098	0.040	60
1/2" #16	27		0.50	1.26	0.990	0.050	60
1/2" #13	57		0.50	1.26	0.132	0.080	57
3/4" #18	15		0.92	2.10	0.118	0.040	75
3/4" #16	18		0.92	2.10	0.118	0.050	75
3/4" #13	27		0.92	2.10	0.120	0.070	75
3/4" #9	62		0.92	2.10	0.150	0.119	61
1-1/2" #16	14		1.33	3.15	0.128	0.050	80
1-1/2" #13	21		1.33	3.15	0.130	0.079	80
1-1/2" #9	42		1.33	3.15	0.165	0.119	75

All weights, gauges and dimensions are approximate.

Expanded Metal - Flat. Weights and Dimensions

ALUMINUM - FLAT

STYLE	LBS. PER 4 X 8 SHEET	DESIGN SIZE (IN.)		STRAND WIDTH (IN.)	OVERALL THICKNESS (IN.)	% OPEN AREA
	PLAIN	SWD	LWD	WIDTH		
3/16" 0.032	7	0.20	0.50	0.095	0.040	55
1/2" 0.051	8	0.50	1.27	0.104	0.040	61
1/2" 0.081	14	0.50	1.27	0.105	0.060	58
3/4" 0.051	5	0.92	2.13	0.122	0.040	72
3/4" 0.081 (L)	10	0.92	2.13	0.143	0.070	70
3/4" 0.081 (H)	13	0.92	2.13	0.181	0.070	63
3/4" 0.125	20	0.92	2.13	0.187	0.095	62
3/4" 0.187	34	0.92	2.00	0.221	0.180	61
1-1/2" 0.081	7	1.33	3.15	0.143	0.081	81
1-1/2" 0.125	13	1.33	3.15	0.181	0.120	76

All weights, gauges and dimensions are approximate.

Expanded Flat - Sample Patterns and Measurements

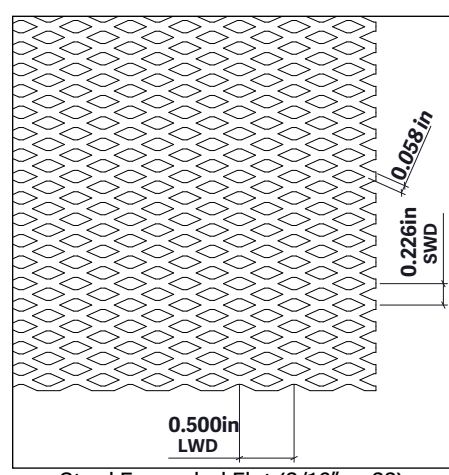

Steel Expanded Flat (3/16" - #22)

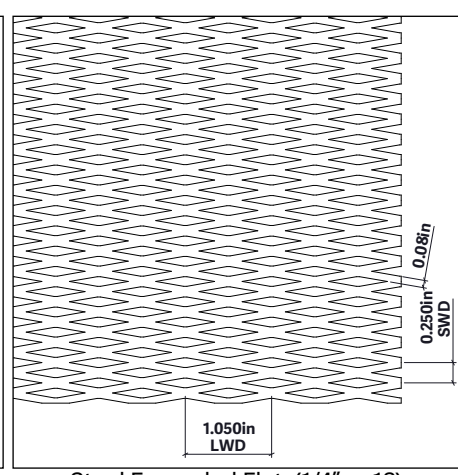

Steel Expanded Flat (1/4" - #18)

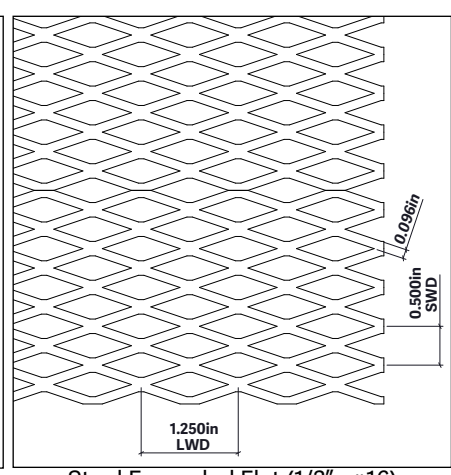

Steel Expanded Flat (1/2" - #16)

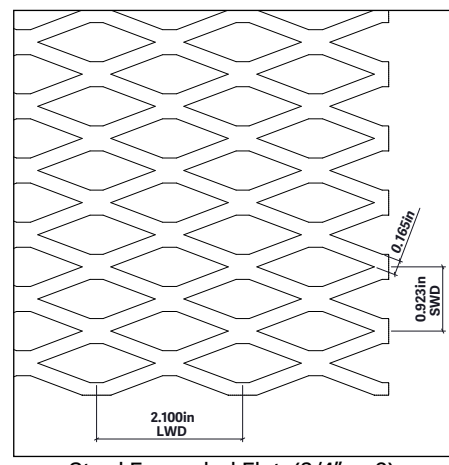

Steel Expanded Flat (3/4" - #9)

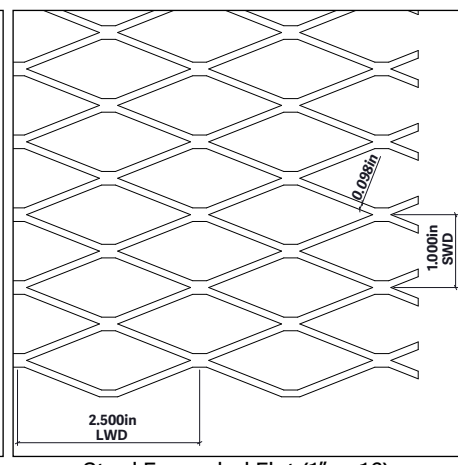

Steel Expanded Flat (1" - #16)

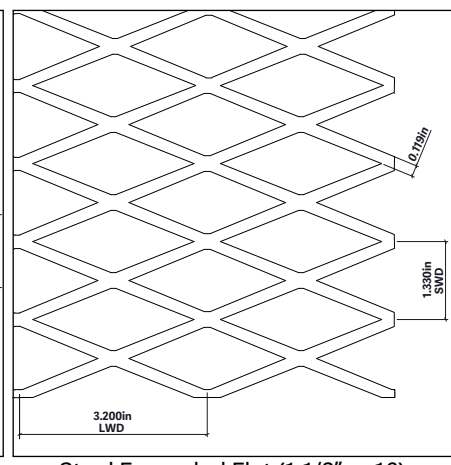

Steel Expanded Flat (1-1/2" - #16)

Expanded Metal - Raised. Weights and Dimensions

CARBON STEEL – RAISED							
STYLE	LBS. PER 4 X 8 SHEET		DESIGN SIZE (IN.)		STRAND WIDTH (IN.)	OVERALL THICKNESS (IN.)	% OPEN AREA
	PLAIN	GALV. WT.	SWD	LWD	WIDTH		
3/16 #22	18	N/R	0.20	0.50	0.047	0.070	55
3/16 #20	29	N/R	0.20	0.50	0.063	0.080	40
1/4" #20	28	N/R	0.31	1.00	0.072	0.130	54
1/4" #18	37	N/R	0.31	1.00	0.072	0.130	54
5/16" #20	18	N/R	0.33	1.00	0.063	0.125	60
5/16" #18	33	N/R	0.33	1.00	0.094	0.170	48
1/2" #20	14	16	0.50	1.20	0.072	0.140	80
1/2" #18	23	27	0.50	1.20	0.088	0.172	72
1/2" #16	28	31	0.50	1.20	0.087	0.175	65
1/2" #13	47	55	0.50	1.20	0.096	0.204	57
3/4" #16	17	21.0	0.92	2.00	0.101	0.210	78
3/4" #13	26	30	0.92	2.00	0.096	0.205	76
3/4" #10 (13ga)	39	44	0.92	2.00	0.144	0.290	72
3/4" #9 (10ga)	58	63	0.92	2.00	0.150	0.312	68
1" #16	14	16	1.00	2.40	0.087	0.192	82
1" #14	25	29	1.00	2.25	0.125	0.225	75
1" #12	31	35	1.00	2.25	0.109	0.225	78
1" #10H	64	71	1.00	2.25	0.180	0.390	60
1" #7	115	121	1.00	2.25	0.240	0.450	52
1-1/2" #16	13	15	1.33	3.00	0.108	0.230	85
1-1/2" #13	19	22	1.33	3.00	0.105	0.242	85
1-1/2" #12	24	27	1.33	3.00	0.109	0.225	83
1-1/2" #10 (13ga)	25	28	1.33	3.00	0.138	0.284	80
1-1/2" #9 (10ga)	39	42	1.33	3.00	0.144	0.312	76
1-1/2" #10H	64	71	1.33	3.00	0.240	0.460	72
1-1/2" #6 (6ga)	80	87	1.33	3.00	0.203	0.433	69
STAINLESS STEEL – RAISED							
STYLE	LBS. PER 4 X 8 SHEET		DESIGN SIZE (IN.)		STRAND WIDTH (IN.)	OVERALL THICKNESS (IN.)	% OPEN AREA
	PLAIN		SWD	LWD	WIDTH		
1/4" #18	31		0.31	1.00	0.072	0.140	54
1/2" #20	16		0.50	1.20	0.080	0.164	70
1/2" #18	23		0.50	1.20	0.087	0.164	70
1/2" #16	29		0.50	1.20	0.087	0.164	70
1/2" #13	60		0.50	1.20	0.119	0.225	70
3/4" #18	15		0.92	2.00	0.106	0.200	85
3/4" #16	17		0.92	2.00	0.106	0.202	83
3/4" #13	29		0.92	2.00	0.107	0.202	80
3/4" #9 (10ga)	65		0.92	2.00	0.160	0.300	67
1-1/2" #16	14		1.33	3.00	0.115	0.222	85
1-1/2" #13	22		1.33	3.00	0.115	0.222	83
1-1/2" #9 (10ga)	44		1.33	3.00	0.155	0.280	77

All weights, gauges and dimensions are approximate.

Expanded Metal - Raised. Weights and Dimensions

ALUMINUM - RAISED

STYLE	LBS. PER 4 X 8 SHEET	DESIGN SIZE (IN.)		STRAND WIDTH (IN.)	OVERALL THICKNESS (IN.)	% OPEN AREA
	PLAIN	SWD	LWD	WIDTH		
3/16" 0.032	9	0.21	0.13	0.032	0.095	42
1/2" 0.051	9	0.50	1.20	0.093	0.158	65
1/2" 0.081	14	0.50	1.20	0.081	0.186	60
3/4" 0.051	6	0.92	2.00	0.051	0.200	78
3/4" 0.081 (L)	10	0.92	2.00	0.081	0.220	76
3/4" 0.081 (H)	13	0.92	2.00	0.081	0.300	69
3/4" 0.125	21	0.92	2.00	0.125	0.305	68
3/4" 0.187	34	1.15	3.00	0.180	0.180	61
1-1/2" 0.081	7	1.33	3.00	0.081	0.240	85
1-1/2" 0.125	13	1.33	3.00	0.162	0.3	79

All weights, gauges and dimensions are approximate.

Expanded Raised - Sample Patterns and Measurements

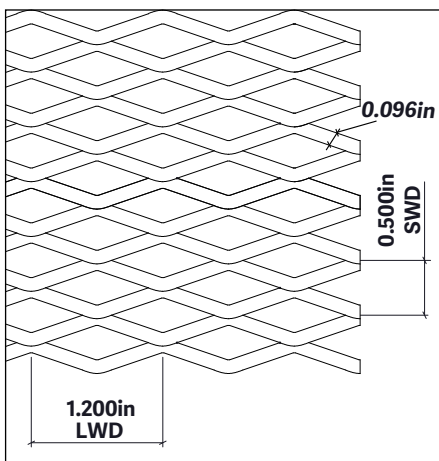

Steel Expanded Raised (1/2" - #13)

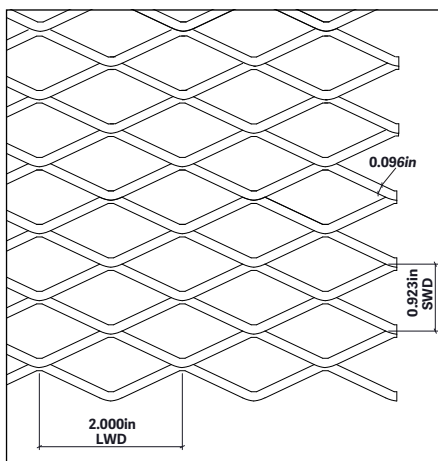

Steel Expanded Raised (3/4" - #13)

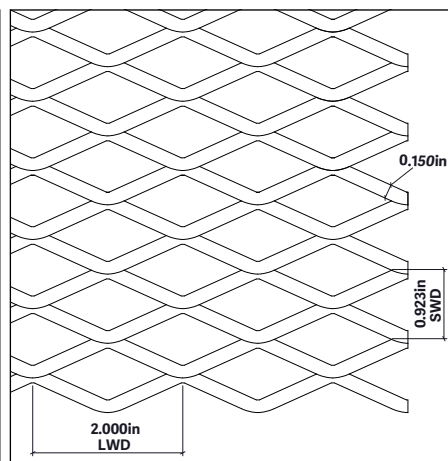

Steel Expanded Raised (3/4" - #9 10ga)

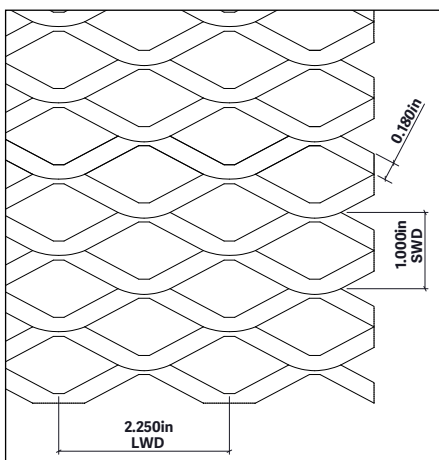

Steel Expanded Raised (1" - #10H)

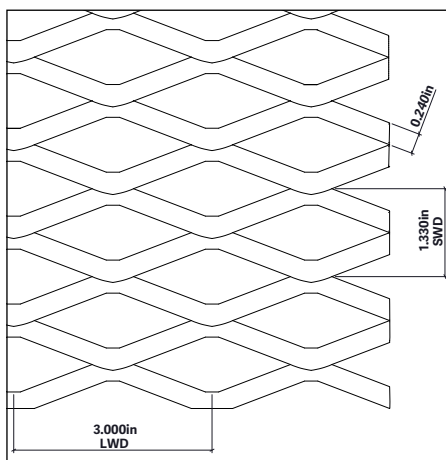

Steel Expanded Raised (1-1/2" - #10H)

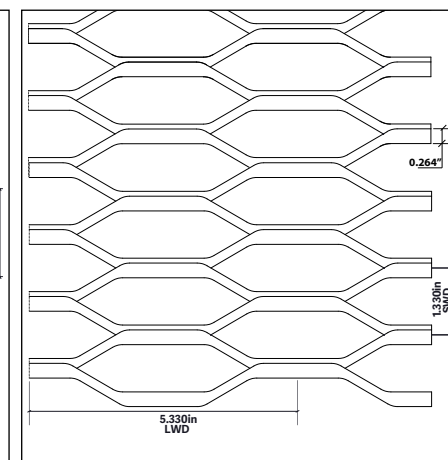

Steel Expanded Grating (3LB)

Expanded Grating



The manufacturing process that produces expanded grating is similar to that of expanded metal. The difference is in the thickness (gauge) of the strand. Expanded grating has a thicker strand gauge which affords it load bearing characteristics and therefore lends itself to a wider variety of applications.

STEEL GRATING SPECIFICATIONS FOR 48 SWD STOCK SHEETS

STYLE	LBS. PER 4 X 8 SHEET	DESIGN SIZE (IN.)		STRAND WIDTH (IN.)	OVERALL THICKNESS (IN.)	% OPEN AREA
	PLAIN	SWD	LWD	WIDTH		
3 lb.	96.0	1.330	5.330	0.264	0.540	60
3.14 lb.	100.5	2.000	6.000	0.312	0.656	69
4 lb.	128.0	1.330	5.330	0.300	0.618	55
4.27 lb.	137.0	1.410	4.000	0.300	0.625	58
5 lb.	160.0	1.330	5.330	0.331	0.655	50
6.25 lb.	200.0	1.410	5.330	0.350	0.715	50
7 lb.	224.0	1.410	5.330	0.391	0.740	45

STAINLESS 304 GRATING SPECIFICATIONS FOR 48 SWD STOCK SHEETS

STYLE	LBS. PER 4 X 8 SHEET	DESIGN SIZE (IN.)		STRAND WIDTH (IN.)	OVERALL THICKNESS (IN.)	% OPEN AREA
	PLAIN	SWD	LWD	WIDTH		
3.3 lb.	105.5	2.00	6.0	0.312	0.656	69
4.5 lb.	144.0	1.41	4.0	0.300	0.625	58

ALUMINUM 5052 H-32 GRATING SPECIFICATIONS FOR 48 SWD STOCK SHEETS

STYLE	LBS. PER 4 X 8 SHEET	DESIGN SIZE (IN.)		STRAND WIDTH (IN.)	OVERALL THICKNESS (IN.)	% OPEN AREA
	PLAIN	SWD	LWD	WIDTH		
2.0 lb.	64.0	1.33	5.33	0.387	0.730	48

All weights, gauges and dimensions are approximate.

Expanded Metal Terminology

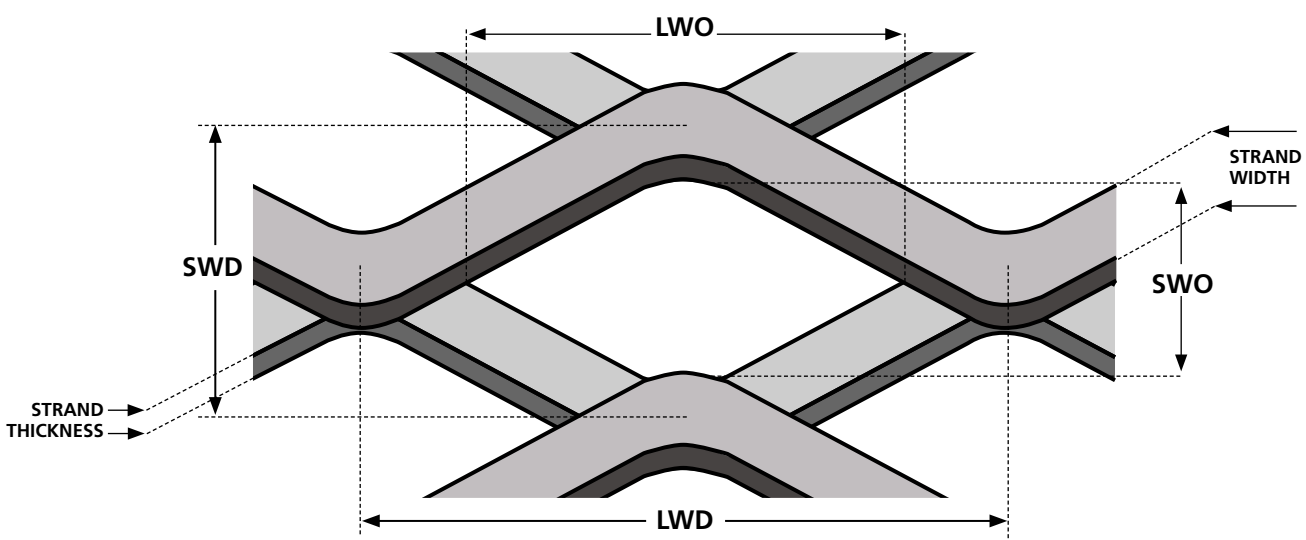

DESIGN SIZE - Actual Dimension **SWD** and **LWD** measured from a point to a corresponding point on the design above.

STRAND THICKNESS - Gauge of metal.

STRAND WIDTH - Amount of metal fed under dies to produce metal strand.

SWO - Short Way of Opening

LWO - Long Way of Opening

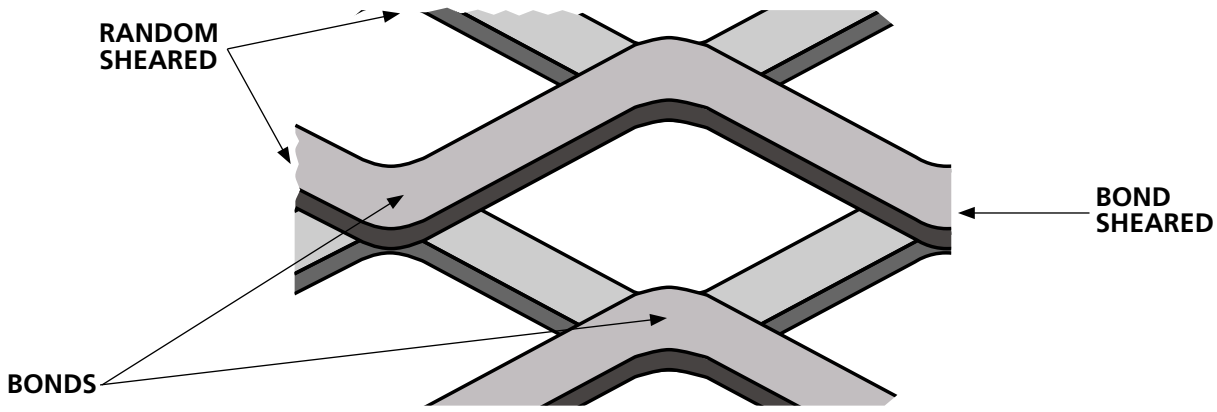

BOND - Where two strands intersect. Eliminates prongs or jagged edges.

RANDOM - This type of shearing leaves prongs or jagged edges.

TOLERANCE - Minus 0 plus 1/2 the design size whether SWD or LWD

Bar Grating - Tolerances

Non HD Steel & Aluminum Grating (for HD Tolerances go to www accuratescreen.ca)

Overall Dimensions and Squareness

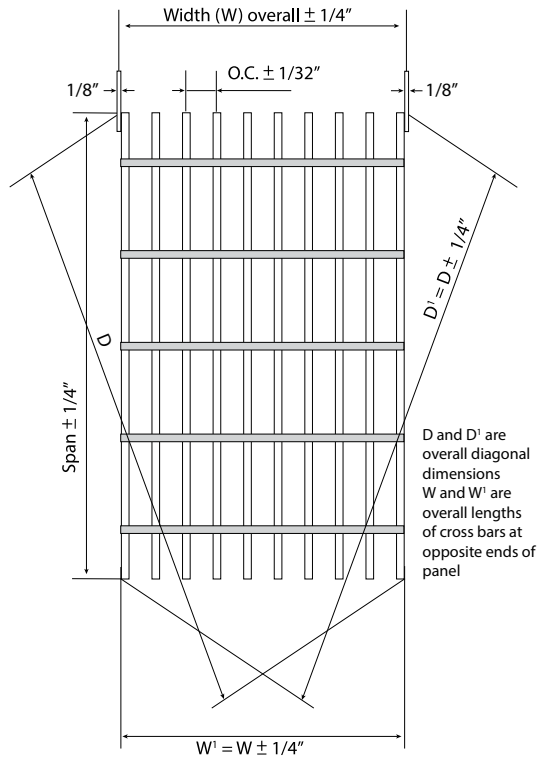

Cross Bar Alignment and Spacing

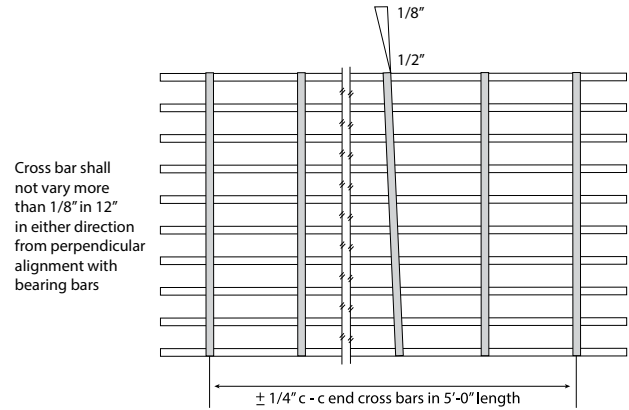

Cross Bar Location

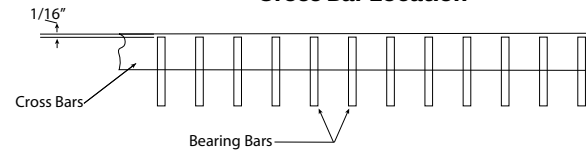

Bearing Bar Lean

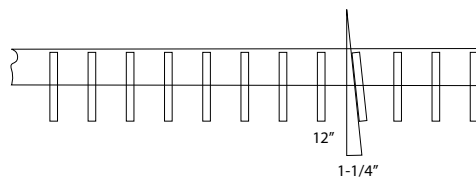

Cross Bar Lean

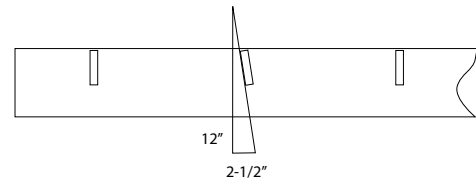

Longitudinal Bow

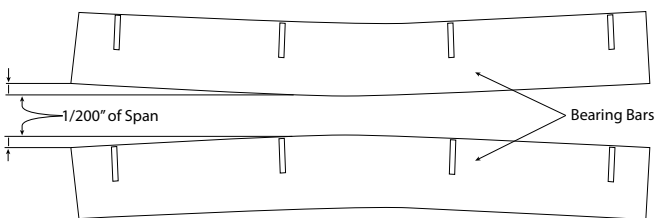

Transverse Bow (Before fastening to supports)

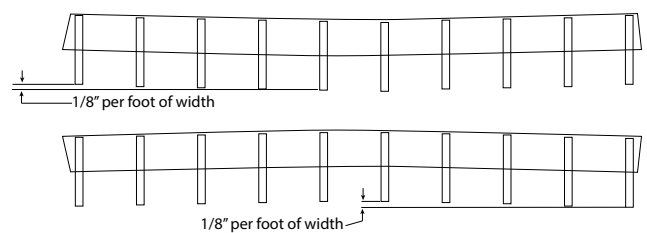

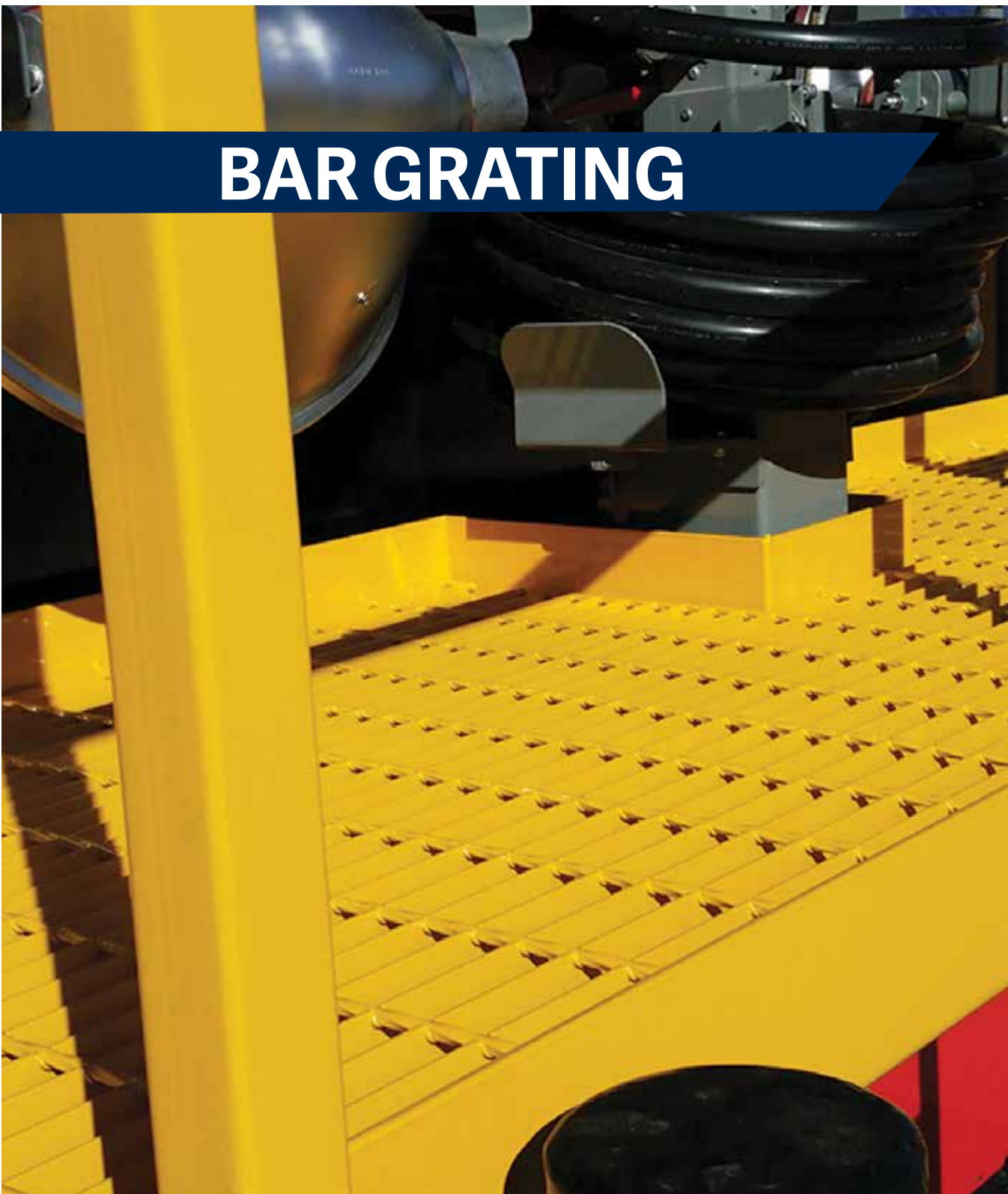

BAR GRATING

The specifications contained within this section refer only to 19-4 spaced Bar Grating. For complete specifications on all available Bar Grating configurations refer to the Accurate Screen Grating Catalogue or visit our website www accuratescreen.ca

Bar Grating - Steel 19-4

TABLE OF SAFE LOADS

U - Safe Uniform Load, in lbs. per sq. ft.
 C - Safe Concentrated Load, in lbs. per foot of grating width
 D - Deflection in inches

For serrated surface, increase depth by 1/4" for load rate.

GENERAL

Loads and deflections are theoretical and based on static loading.

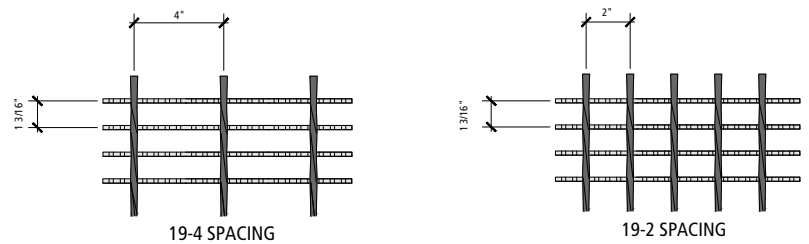

STANDARD STEEL TYPE 19-4

SIZE OF BEARING BAR	APPROX. WT/LBS/SQ.FT		SPAN IN INCHES																	SEC. MOD. PER FEET OF WIDTH			
	TYPE 19-4	TYPE 19-2	1'-0"	1'-6"	2'-0"	2'-6"	3'-0"	3'-6"	4'-0"	4'-6"	5'-0"	5'-6"	6'-0"	6'-6"	7'-0"	8'-0"	9'-0"						
3/4" X 1/8"	3.93		U	1420	631	355	227	158	116	89	70									0.122			
			D	0.023	0.055	0.099	0.155	0.223	0.304	0.397	0.503												
			C	710	473	355	284	237	203	178	158												
3/4" X 3/16"	5.58		D	0.019	0.044	0.079	0.124	0.179	0.243	0.318	0.402								0.183				
			U	2132	948	533	341	237	174	133	105												
			D	0.023	0.055	0.099	0.155	0.223	0.304	0.397	0.503												
1" X 1/8"	5.03	5.50	C	1066	711	533	426	355	305	266	237										0.216		
			D	0.019	0.044	0.079	0.124	0.179	0.243	0.318	0.402												
			U	2528	1124	632	404	281	206	158	125	101	84										
1" X 3/16"	7.23	7.87	D	0.020	0.042	0.074	0.116	0.168	0.228	0.298	0.377	0.466	0.563									0.325	
			C	1264	843	632	505	421	361	316	281	253	230										
			D	0.018	0.035	0.060	0.093	0.134	0.182	0.238	0.302	0.372	0.451										
1 1/4" X 1/8"	6.12	6.76	U	3788	1684	947	606	421	309	237	187	152	125							0.339			
			D	0.020	0.042	0.074	0.116	0.168	0.228	0.298	0.377	0.466	0.563										
			C	1894	1263	947	758	632	541	474	421	379	344										
1 1/4" X 3/16"	8.87	9.51	D	0.018	0.035	0.060	0.093	0.134	0.182	0.238	0.302	0.372	0.451						0.507				
			U	3948	1755	987	632	439	322	247	195	158	130	110	93	81							
			D	0.017	0.029	0.048	0.074	0.107	0.146	0.191	0.241	0.298	0.360	0.429	0.504	0.584							
1 1/2" X 1/8"	7.23	7.87	C	1974	1316	987	789	658	564	493	439	395	359	329	304	282					0.488		
			D	0.017	0.029	0.048	0.074	0.107	0.146	0.191	0.241	0.298	0.360	0.429	0.504	0.584							
			U	5920	2631	1480	947	658	483	370	292	237	196	164	140	121							
1 1/2" X 3/16"	10.51	11.15	D	0.018	0.035	0.060	0.093	0.134	0.182	0.238	0.302	0.372	0.451	0.536	0.629	0.730						0.730	
			C	2960	1973	1480	1184	987	846	740	658	592	538	493	455	423							
			D	0.017	0.029	0.048	0.074	0.107	0.146	0.191	0.241	0.298	0.360	0.429	0.504	0.584							
1 3/4" X 1/8"	12.17	12.81	U	5684	2526	1421	909	632	464	355	281	227	188	158	135	116	89	70		0.994			
			D	0.012	0.028	0.050	0.078	0.112	0.152	0.199	0.251	0.310	0.376	0.447	0.524	0.608	0.794	1.006					
			C	2842	1895	1421	1137	947	812	711	632	568	517	474	437	406	355	316					
2" X 3/16"	13.81	14.45	D	0.011	0.023	0.040	0.062	0.089	0.122	0.159	0.201	0.248	0.300	0.358	0.420	0.487	0.636	0.804	1.299				
			U	11604	5157	2901	1857	1289	947	725	573	464	384	322	275	237	181	143					
			D	0.010	0.024	0.043	0.067	0.096	0.130	0.170	0.215	0.266	0.322	0.383	0.450	0.521	0.681	0.862					
2 1/4" X 3/16"	15.45	16.09	C	5802	3868	2901	2321	1934	1658	1451	1289	1161	1055	967	893	829	725	645			1.644		
			D	0.011	0.020	0.034	0.053	0.077	0.104	0.136	0.172	0.213	0.257	0.306	0.360	0.417	0.545	0.689					
			U	15156	6736	3789	2425	1684	1237	947	749	606	501	421	359	309	237	187					
2 1/2" X 3/16"	17.11	17.75	D	0.010	0.021	0.037	0.058	0.084	0.114	0.149	0.189	0.233	0.282	0.335	0.393	0.456	0.596	0.754				2.029	
			C	7578	5052	3789	3032	2526	2165	1895	1684	1516	1378	1263	1166	1083	947	842					
			D	0.005	0.016	0.030	0.047	0.067	0.091	0.119	0.151	0.186	0.225	0.268	0.315	0.365	0.477	0.603					
2 1/2" X 3/16"	17.11	17.75	U	19184	8526	4796	3069	2132	1566	1199	947	767	634	533	454	392	300	237		1.644			
			D	0.004	0.017	0.033	0.052	0.074	0.101	0.132	0.168	0.207	0.250	0.298	0.350	0.406	0.530	0.670					
			C	9592	6395	4796	3837	3197	2741	2398	2132	1918	1744	1599	1476	1370	1199	1066					
2 1/2" X 3/16"	17.11	17.75	D	0.008	0.015	0.026	0.041	0.060	0.081	0.106	0.134	0.166	0.200	0.238	0.280	0.324	0.424	0.536	2.029				
			U	23684	10526	5921	3789	2632	1933	1480	1170	947	783	658	561	483	370	292					
			D	0.005	0.016	0.030	0.047	0.067	0.091	0.119	0.151	0.186	0.225	0.268	0.315	0.365	0.477	0.603					
2 1/2" X 3/16"	17.11	17.75	C	11842	7895	5921	4737	3947	3383	2961	2632	2368	2153	1974	1822	1692	1480	1316			2.029		
			D	0.010	0.015	0.024	0.037	0.054	0.073	0.095	0.121	0.149	0.180	0.215	0.252	0.292	0.381	0.483					

Note: Spans to the right of heavy line not recommended. Deflections shown based on tabulated loadings. For lesser design loads reduce deflection in direct proportion. For serrated surface increase depth by one size.

Maximum allowable fiber stress of 18,000 P.S.I

Bar Grating - Stainless Steel 19-4

TABLE OF SAFE LOADS - IMPERIAL

U - Safe Uniform Load, in lbs. per sq. ft.
 C - Safe Concentrated Load, in lbs. per foot of grating width
 D - Deflection in inches

For serrated surface, increase depth by 1/4" for load rate.

GENERAL

Loads and deflections are theoretical and based on static loading.

Note: Spans to the right of heavy line not recommended. Deflections shown based on tabulated loadings. For lesser design loads reduce deflection in direct proportion. For serrated surface increase depth by one size.

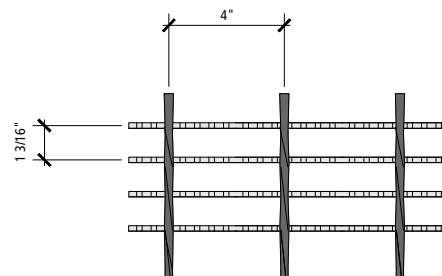

19-4 SPACING

		304 & 316 STAINLESS STEEL TYPE 19-4															
SIZE OF BEARING BAR	APPROX. WT/LBS/SQ.FT TYPE 19-4	SPAN IN INCHES															
		1'-0"	1'-6"	2'-0"	2'-6"	3'-0"	3'-6"	4'-0"	4'-6"	5'-0"	5'-6"	6'-0"	6'-6"	7'-0"	8'-0"	9'-0"	
3/4" X 1/8"	3.93	U	1578	701	394	252	176	129	99	78							
		D	0.026	0.063	0.114	0.178	0.257	0.350	0.457	0.579							
		C	789	526	394	316	263	226	198	176							
		D	0.022	0.051	0.091	0.143	0.206	0.280	0.366	0.463							
3/4" X 3/16"	5.64	U	2369	1053	592	379	263	193	148	117							
		D	0.026	0.063	0.114	0.178	0.257	0.350	0.457	0.579							
		C	1184	790	592	473	394	339	296	263							
		D	0.022	0.051	0.091	0.143	0.206	0.280	0.366	0.463							
1" X 1/8"	4.99	U	2809	1248	702	449	312	229	176	139	112	93					
		D	0.023	0.048	0.085	0.134	0.193	0.262	0.343	0.434	0.536	0.648					
		C	1404	936	702	561	468	401	351	312	281	256					
		D	0.021	0.040	0.069	0.107	0.154	0.209	0.274	0.348	0.428	0.519					
1" X 3/16"	7.19	U	4208	1870	1052	673	468	343	263	208	169	139					
		D	0.023	0.048	0.085	0.134	0.193	0.262	0.343	0.434	0.536	0.648					
		C	2104	1403	1052	842	702	601	527	468	421	382					
		D	0.021	0.040	0.069	0.107	0.154	0.209	0.274	0.348	0.428	0.519					
1 1/4" X 1/8"	6.09	U	4386	1949	1097	702	488	358	274	217	176	144	122	103	90		
		D	0.021	0.040	0.069	0.107	0.154	0.209	0.274	0.348	0.428	0.519	0.617	0.724	0.840		
		C	2193	1462	1097	877	731	627	548	488	439	399	366	338	313		
		D	0.020	0.033	0.055	0.085	0.123	0.168	0.220	0.277	0.343	0.414	0.494	0.580	0.672		
1 1/4" X 3/16"	8.84	U	6577	2923	1644	1052	731	537	411	324	263	218	182	156	134		
		D	0.021	0.040	0.069	0.107	0.154	0.209	0.274	0.348	0.428	0.519	0.617	0.724	0.840		
		C	3289	2192	1644	1315	1097	940	822	731	658	598	548	506	470		
		D	0.020	0.033	0.055	0.085	0.123	0.168	0.220	0.277	0.343	0.414	0.494	0.580	0.672		
1 1/2" X 1/8"	7.19	U	6315	2807	1579	1010	702	516	394	312	252	209	176	150	129	99	78
		D	0.014	0.032	0.058	0.090	0.129	0.175	0.229	0.289	0.357	0.433	0.514	0.603	0.700	0.914	1.158
		C	3157	2105	1579	1263	1052	902	790	702	631	574	527	486	451	394	351
		D	0.013	0.026	0.046	0.071	0.102	0.140	0.183	0.231	0.285	0.345	0.412	0.483	0.561	0.732	0.925
1 1/2" X 3/16"	10.48	U	9475	4211	2369	1515	1052	773	592	468	379	313	263	224	193	148	117
		D	0.014	0.032	0.058	0.090	0.129	0.175	0.229	0.289	0.357	0.433	0.514	0.603	0.700	0.914	1.158
		C	4737	3158	2369	1894	1579	1353	1184	1052	948	861	790	729	677	592	527
		D	0.013	0.026	0.046	0.071	0.102	0.140	0.183	0.231	0.285	0.345	0.412	0.483	0.561	0.732	0.925
1 3/4" X 3/16"	11.71	U	12892	5730	3223	2063	1432	1052	805	637	516	427	358	306	263	201	159
		D	0.012	0.028	0.049	0.077	0.110	0.150	0.196	0.247	0.306	0.371	0.441	0.518	0.600	0.784	0.992
		C	6446	4297	3223	2579	2149	1842	1612	1432	1290	1172	1074	992	921	805	717
		D	0.013	0.023	0.039	0.061	0.089	0.120	0.157	0.198	0.245	0.296	0.352	0.414	0.480	0.627	0.793
2" X 3/16"	13.78	U	16838	7484	4210	2694	1871	1374	1052	832	673	557	468	399	343	263	208
		D	0.012	0.024	0.043	0.067	0.097	0.131	0.171	0.218	0.268	0.325	0.386	0.452	0.525	0.686	0.868
		C	8419	5613	4210	3369	2806	2405	2105	1871	1684	1531	1403	1295	1203	1052	935
		D	0.006	0.018	0.035	0.054	0.077	0.105	0.137	0.174	0.214	0.259	0.308	0.363	0.420	0.549	0.694
2 1/4" X 3/16"	15.49	U	21313	9473	5328	3410	2369	1740	1332	1052	852	704	592	504	436	333	263
		D	0.005	0.020	0.038	0.060	0.085	0.116	0.152	0.193	0.238	0.288	0.343	0.403	0.467	0.610	0.771
		C	10657	7104	5328	4263	3552	3045	2664	2369	2131	1938	1776	1640	1522	1332	1184
		D	0.009	0.017	0.030	0.047	0.069	0.093	0.122	0.154	0.191	0.230	0.274	0.322	0.373	0.488	0.617
2 1/2" X 3/16"	17.08	U	26313	11695	6578	4210	2924	2148	1644	1300	1052	870	731	623	537	411	324
		D	0.006	0.018	0.035	0.054	0.077	0.105	0.137	0.174	0.214	0.259	0.308	0.363	0.420	0.549	0.694
		C	13156	8771	6578	5263	4385	3759	3290	2924	2631	2392	2193	2024	1880	1644	1462
		D	0.012	0.017	0.028	0.043	0.062	0.084	0.109	0.139	0.171	0.207	0.247	0.290	0.336	0.439	0.556

Maximum allowable fiber stress of 18,000 P.S.I

Bar Grating - Aluminum 19-4

TABLE OF SAFE LOADS

U - Safe Uniform Load, in lbs. per sq. ft.

C - Safe Concentrated Load, in lbs. per foot of grating width

D - Deflection in inches

For serrated surface, increase depth by 1/4" for load rate.

GENERAL

Loads and deflections are theoretical and based on static loading.

Note: Spans to the right of heavy line not recommended. Deflections shown based on tabulated loadings. For lesser design loads reduce deflection in direct proportion. For serrated surface increase depth by one size.

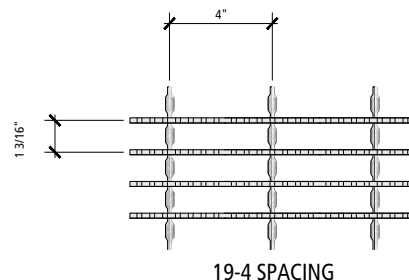

SIZE OF BEARING BAR		APPROX. WT/ LBS/SQ.FT		ALUMINUM TYPE 19-4													SEC. MOD. PER FEET OF WIDTH	
				SPAN IN INCHES														
		TYPE 19-4	TYPE 19-2	1'-0"	1'-6"	2'-0"	2'-6"	3'-0"	3'-6"	4'-0"	4'-6"	5'-0"	5'-6"	6'-0"	6'-6"	7'-0"	8'-0"	
3/4" x 1/8"	1.40	1.60	U	948	421	237	152	105	77									0.118
			D	0.048	0.108	0.192	0.300	0.432	0.588									
			C	474	316	237	189	158	135									
3/4" x 3/16"	1.90	2.10	U	1420	631	355	227	158	116									0.178
			D	0.048	0.108	0.192	0.300	0.432	0.586									
			C	710	473	355	284	237	203									
1" X 1/8"	1.71	1.90	U	1684	748	421	269	187	137	105								0.216
			D	0.036	0.081	0.144	0.225	0.324	0.439	0.576								
			C	842	561	421	337	281	241	211								
1" X 3/16"	2.46	2.70	U	2528	1124	632	404	281	206	158	125							0.325
			D	0.036	0.081	0.144	0.225	0.324	0.441	0.576	0.729							
			C	1264	843	632	505	421	361	316	281							
1 1/4" X 1/8"	2.08	2.30	U	2632	1170	658	421	292	215	164	130							0.339
			D	0.027	0.064	0.115	0.180	0.259	0.353	0.461	0.583							
			C	1316	877	658	526	439	376	329	292							
1 1/4" X 3/16"	3.01	3.30	U	3948	1755	987	632	439	322	247	195	158						0.507
			D	0.027	0.064	0.115	0.180	0.259	0.353	0.461	0.583	0.720						
			C	1974	1316	987	789	658	564	493	439	395						
1 1/2" X 1/8"	2.46	2.70	U	3788	1684	947	606	421	309	237	187	152						0.488
			D	0.024	0.054	0.096	0.150	0.216	0.294	0.384	0.486	0.600						
			C	1894	1263	947	758	632	541	474	421	379						
1 1/2" X 3/16"	3.56	3.90	U	5684	2526	1421	909	632	464	355	281	227	188					0.730
			D	0.024	0.054	0.096	0.150	0.216	0.294	0.384	0.486	0.600	0.726					
			C	2842	1895	1421	1137	947	812	711	632	568	517					
1 3/4" X 3/16"	4.12	4.40	U	7736	3438	1934	1238	860	632	484	382	309	256	215	183			0.994
			D	0.015	0.044	0.082	0.129	0.185	0.252	0.329	0.417	0.514	0.622	0.741	0.869			
			C	3868	2579	1934	1547	1289	1105	967	860	774	703	645	595			
2" X 3/16"	4.68	5.00	U	10104	4491	2526	1617	1123	825	632	499	404	334	281	239	206		1.299
			D	0.014	0.039	0.072	0.113	0.162	0.221	0.288	0.365	0.450	0.545	0.648	0.761	0.882		
			C	5052	3368	2526	2021	1684	1444	1263	1123	1011	919	842	777	722		
2 1/4" X 3/16"	5.24	5.80	U	12788	5684	3197	2046	1421	1044	799	632	512	423	355	303	261	200	1.644
			D	0.016	0.036	0.064	0.100	0.144	0.196	0.256	0.324	0.400	0.484	0.576	0.676	0.784	1.024	
			C	6394	4263	3197	2558	2132	1827	1599	1421	1279	1163	1066	984	914	799	
2 1/2" X 3/16"	5.79	6.10	U	15788	7017	3947	2526	1454	1289	987	780	632	522	439	374	322	247	2.029
			D	0.018	0.034	0.058	0.090	0.130	0.176	0.230	0.292	0.360	0.436	0.518	0.608	0.706	0.922	
			C	7894	5263	3947	3158	2632	2256	1974	1754	1579	1435	1316	1215	1128	987	
			D	0.012	0.026	0.046	0.072	0.104	0.141	0.184	0.233	0.288	0.348	0.415	0.487	0.564	0.737	

Maximum allowable fiber stress of 18,000 P.S.I

Bar Grating - Treads

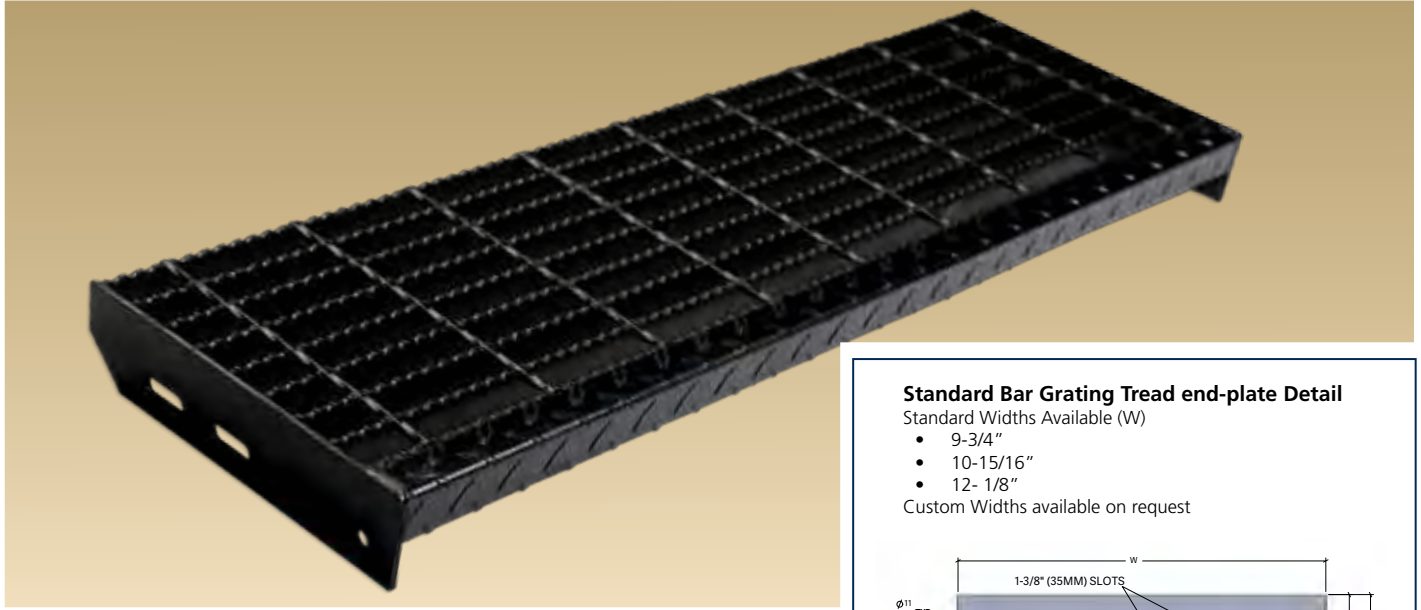

Standard Bar Grating Tread end-plate Detail

Standard Widths Available (W)

- 9-3/4"
- 10-15/16"
- 12- 1/8"

Custom Widths available on request

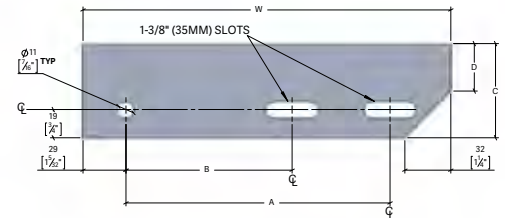

STAIR TREAD WEIGHTS (LBS)							
MATERIAL	TREAD WIDTH (INCHES)	BEARING BAR SIZE					
		1" x 1/8"	1-1/4" x 1/8"	3/4" x 3/16"	1" x 3/16"	1-1/4" x 3/16"	1-1/2" x 3/16"
		LB. PER LINEAL INCH OF TREAD LENGTH					
Steel	6-3/16	0.29	0.32	0.31	0.36	0.41	0.48
Steel	7-7/8	0.34	0.38	0.36	0.43	0.49	0.55
Steel	8-9/16	0.38	0.43	0.41	0.5	0.57	0.64
Steel	9-3/4	0.43	0.49	0.46	0.56	0.65	0.73
Steel	10-15/16	0.48	0.55	0.52	0.63	0.73	0.83
Steel	12-1/8	0.53	0.6	0.58	0.7	0.81	0.92
If galvanized steel - multiply lb. per lineal inch by a factor of 1.10							
Aluminum	6-3/16	0.10	0.11	0.10	0.12	0.14	0.16
Aluminum	7-7/8	0.11	0.13	0.12	0.14	0.16	0.18
Aluminum	8-9/16	0.13	0.14	0.14	0.17	0.19	0.21
Aluminum	9-3/4	0.14	0.16	0.15	0.18	0.21	0.24
Aluminum	10-15/16	0.16	0.18	0.17	0.21	0.24	0.27
Aluminum	12-1/8	0.17	0.20	0.19	0.23	0.27	0.30

STANDARD END PLATE DIMENSIONS						
# of Bars	Tread Width (W)		Outer Slot (A)		Inner Slot (B)	
	Metric (mm)	Imperial (in)	Metric (mm)	Imperial (in)	Metric (mm)	Imperial (in)
8	248	9-3/4	178	7	112	4-1/2
9	278	10-15/16	178	7	112	4-1/2
10	308	12-1/8	178	7	112	4-1/2

Grating Height	Dimension (C)	Dimension (D)	Dimension (E)
Metric (mm)	Imperial (in)	Metric (mm)	Imperial (in)
Up to 32	Up to 1-1/4	64	2-1/2
		32	1-1/4
		5	3/16
38 to 44	1-1/2 to 1-3/4	76	3
		44	1-3/4
		6	3/16

MAXIMUM TREAD LENGTH (INCHES)							
MATERIAL	BEARING BAR SIZE	19-4		MATERIAL	BEARING BAR SIZE	19-4	
		1-3/16" o/c				1-3/16" o/c	
		PLAIN	SERRATED			PLAIN	SERRATED
Steel	1 x 1/8	31	27	Aluminum	1 x 1/8	24	21
Steel	1 x 3/16	41	34	Aluminum	1 x 3/16	28	26
Steel	1 x 1/4	49	42	Aluminum	1 x 1/4	31	27
Steel	1-1/4 x 1/8	43	37	Aluminum	1-1/4 x 1/8	30	28
Steel	1-1/4 x 3/16	56	50	Aluminum	1-1/4 x 3/16	34	31
Steel	1-1/4 x 1/4	63	56	Aluminum	1-1/4 x 1/4	38	34
Steel	1-1/2 x 1/8	56	49	Aluminum	1-1/2 x 1/8	36	33
Steel	1-1/2 x 3/16	66	63	Aluminum	1-1/2 x 3/16	42	38
Steel	1-1/2 x 1/4	66	66	Aluminum	1-1/2 x 1/4	47	43
Steel	1-3/4 x 3/16	66	66	Aluminum	1-3/4 x 3/16	51	46
Steel	1-3/4 x 1/4	74	67	Aluminum	1-3/4 x 1/4	58	52
Steel	2 x 3/16	78	72	Aluminum	2 x 3/16	61	56
Steel	2 x 1/4	89	82	Aluminum	2 x 1/4	66	63
Steel	2-1/4 x 3/16	92	85	Aluminum	2-1/4 x 3/16	66	66
Steel	2-1/4 x 1/4	106	97	Aluminum	2-1/4 x 1/4	66	66
Steel	2-1/2 x 3/16	107	100	Aluminum	2-1/2 x 3/16	66	66
Steel	2-1/2 x 1/4	123	114	Aluminum	2-1/2 x 1/4	73	67

- Stair treads supplied with 1/4" x 3/16" plain or serrated 19W4 grating.
- Complete with checker plate nosing and standard end plates.
- Available in bare, painted and galvanized.
- Aluminum and Stainless Steel available.

BAR TO BAR DIMENSIONS (INCHES)						
# OF BARS	BAR THICKNESS					
	0.125	0.1875	0.250	0.313	0.375	
	DISTANCE FROM BAR TO OUTSIDE OF NOSING					
2	2.5625	2.6250	2.6875	2.7500	2.8125	
3	3.7500	3.8125	3.8750	3.9375	4.0000	
4	4.9375	5.0000	5.0625	5.1250	5.1875	
5	6.1250	6.1875	6.2500	6.3125	6.3750	
6	7.3125	7.3750	7.4375	7.5000	7.5625	
7	8.5000	8.5625	8.6250	8.6875	8.7500	
8	9.6875	9.7500	9.8125	9.8750	9.9375	
9	10.8750	10.9375	11.0000	11.0625	11.1250	
10	12.0625	12.1250	12.1875	12.2500	12.3125	

FIBREGLASS GRATING



Fabrication

Perforated

Welded

Woven

Expanded

Bar Grating

Fibreglass

Channel Grating

ALU Deck & Clad
Non-Slip Floor

Wire, Banding
& Fasteners

Architectural

Profiles and Specifications

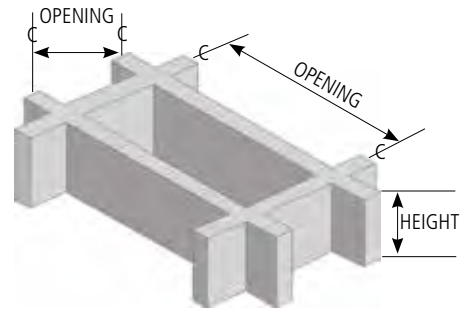
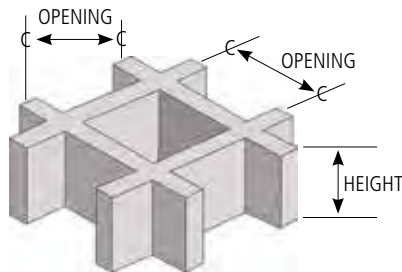
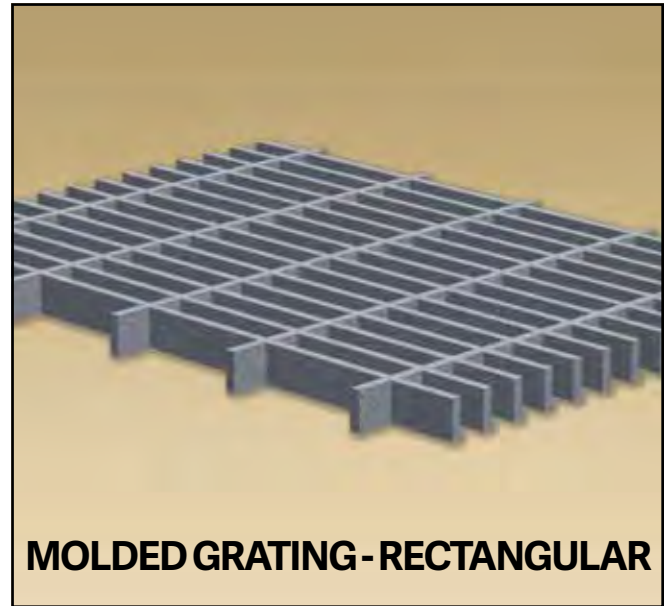
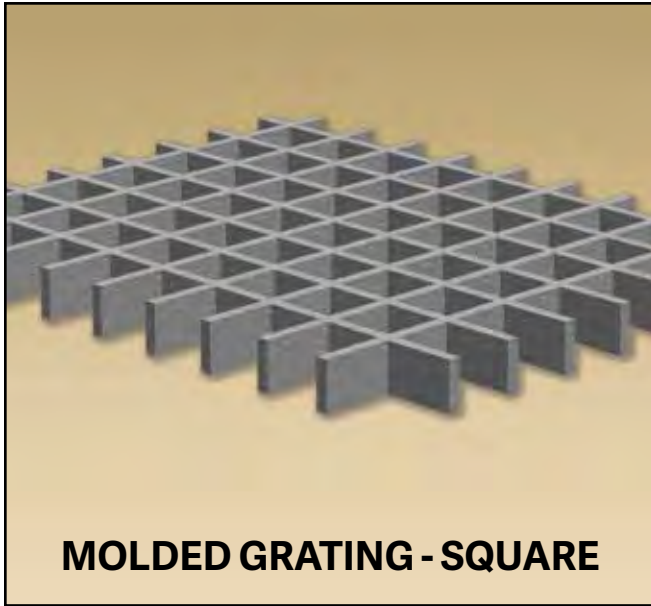

AVAILABLE PROFILES and SIZES (Refer to drawings above for explanation of dimensions)

PROFILE	HEIGHT	OPENING	OPENING	SURFACE
Square	1"	1.5"	1.5"	Smooth or Grit
Square	1.5"	1.5"	1.5"	Smooth or Grit
Square	2"	1.5"	1.5"	Smooth or Grit
Square	2"	2"	2"	Smooth or Grit
Rectangular	1"	1"	4"	Smooth or Grit
Rectangular	1.5"	1.5"	6"	Smooth or Grit

MOLDED FIBREGLASS SPECIFICATIONS:

- Produced in a mold by laying alternating perpendicular rows and columns of glass strands and resin
- IFGR-30
- Isophthalic Polyester (iso resin)
- Desc: Food Grade Corrosion Resistance & Fire Retardant
- Corrosion Resistance: Very Good
- Flame Spread Rating ASTM E84: Class 1, 30 or less
- Bi-directional strength means the span can run in either perpendicular direction
- Grit and non-grit surfaces options
- Available in micro and mini mesh
- Other resins, based on application, are available upon request

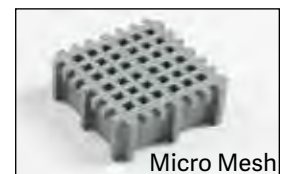

Profiles and Specifications

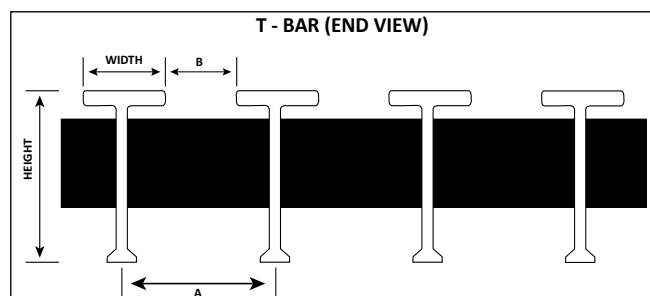
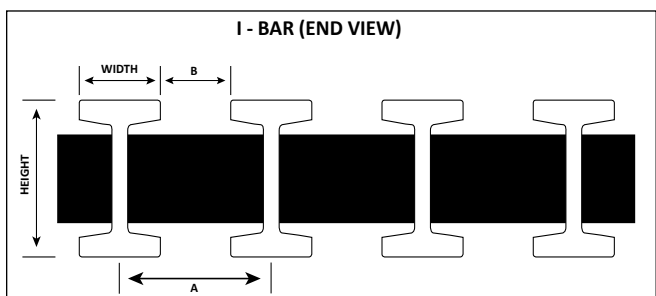
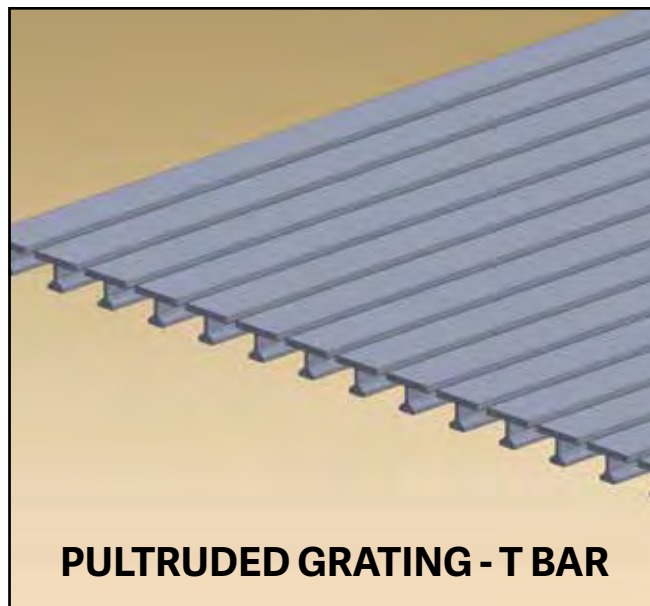
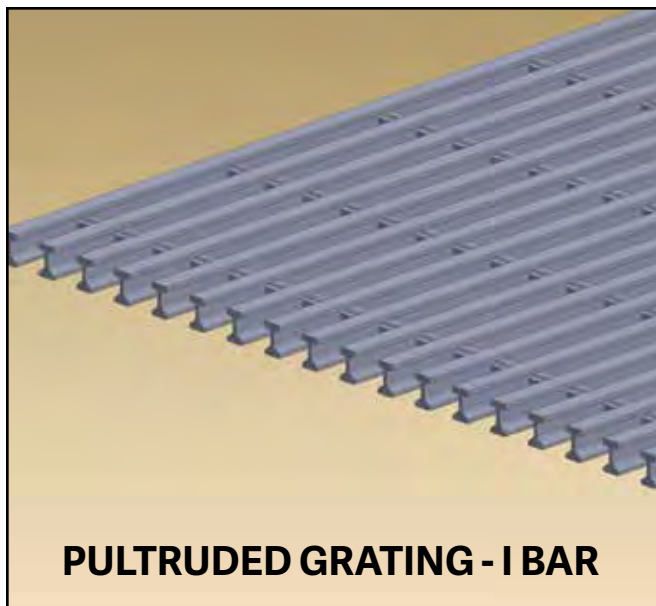

AVAILABLE PROFILES and SIZES (Refer to drawings above for explanation of dimensions)

PROFILE	HEIGHT	WIDTH	Dimension A	Dimension B	SURFACE
I-BAR	1"	.60"	1.5"	.90"	Smooth or Grit
I-BAR	1"	2"	1.5"	.90"	Smooth or Grit
T-BAR	1"	1"	2"	1"	Smooth or Grit

PULTRUDED FIBREGLASS SPECIFICATIONS:

- Produced by pulling glass fibres from spools through a device that coats them with a resin. They are then typically heat-treated and cut to length.
- Isophthalic Polyester (iso resin)
- Desc: Food Grade Corrosion Resistance & Fire Retardant
- Corrosion Resistance: Very Good
- Flame Spread Rating ASTM E84: Class 1, 30 or less
- Produced in long 'bearing bars' and cut to length
- Similar structure to swaged bar grating although the 'cross rods' are 'glued' into place using the same resin which hold together the glass fibres
- Available in I and T profiles
- Grit and non-grit surfaces options
- Other resins, based on application, are available upon request

Fibreglass Treads

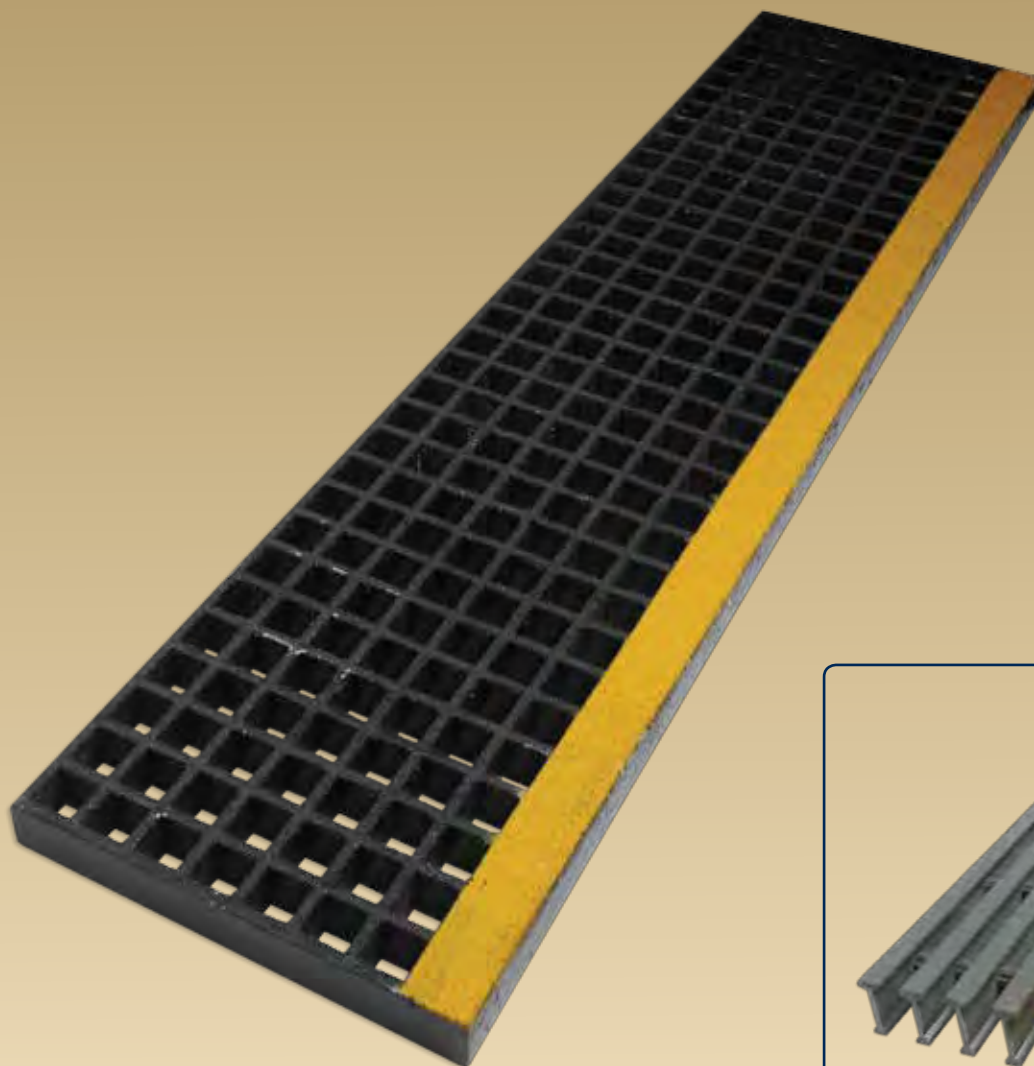

Molded Fiberglass treads are stocked and sold in 12 ft. lengths.



Other Fiberglass treads available. Speak to your ASG rep for custom order requirements.

DEFLECTION IN INCHES - MOLDED GRATING LOAD TABLES - UNIFORM / CONCENTRATED

TREAD SPAN (INCH)	TREAD DEPTH (INCH)	GRATING TYPE		LOAD (LB/SF)								Max Recommended Load (Lb/SF)	Breaking Point (Lb/SF)
		HEIGHT (INCH)	OPENING (INCH)	50	100	150	200	300	500	1000	2000		
18"	12"	1.5	1.5 x 1.5	< .01 / 0.01	0.01 / 0.02	0.02 / 0.02	0.03 / 0.03	0.04 / 0.05	0.07 / 0.08	0.14 / 0.15	0.28 / 0.30	1420 / 1060	7100 / 5330
24"	12"	1.5	1.5 x 1.5	0.02 / 0.02	0.04 / 0.03	0.06 / 0.05	0.08 / 0.07	0.12 / 0.10	0.21 / 0.17	0.42 / 0.33		780 / 800	3900 / 4000
36"	12"	1.5	1.5 x 1.5	0.10 / 0.05	0.20 / 0.11	0.30 / 0.16	0.40 / 0.21					350 / 530	1770 / 2660
48"	12"	1.5	1.5 x 1.5	0.28 / 0.11	0.55 / 0.23							200 / 400	1000 / 2000
60"	12"	1.5	1.5 x 1.5	0.26 / 0.10	0.44 / 0.20								

CHANNEL GRATING



Fabrication

Perforated

Welded

Woven

Expanded

Bar Grating

Fibreglass

Channel Grating

ALU Deck & Clad
Non-Slip Floor

Wire, Banding
& Fasteners

Architectural

Diamond Channel Grating

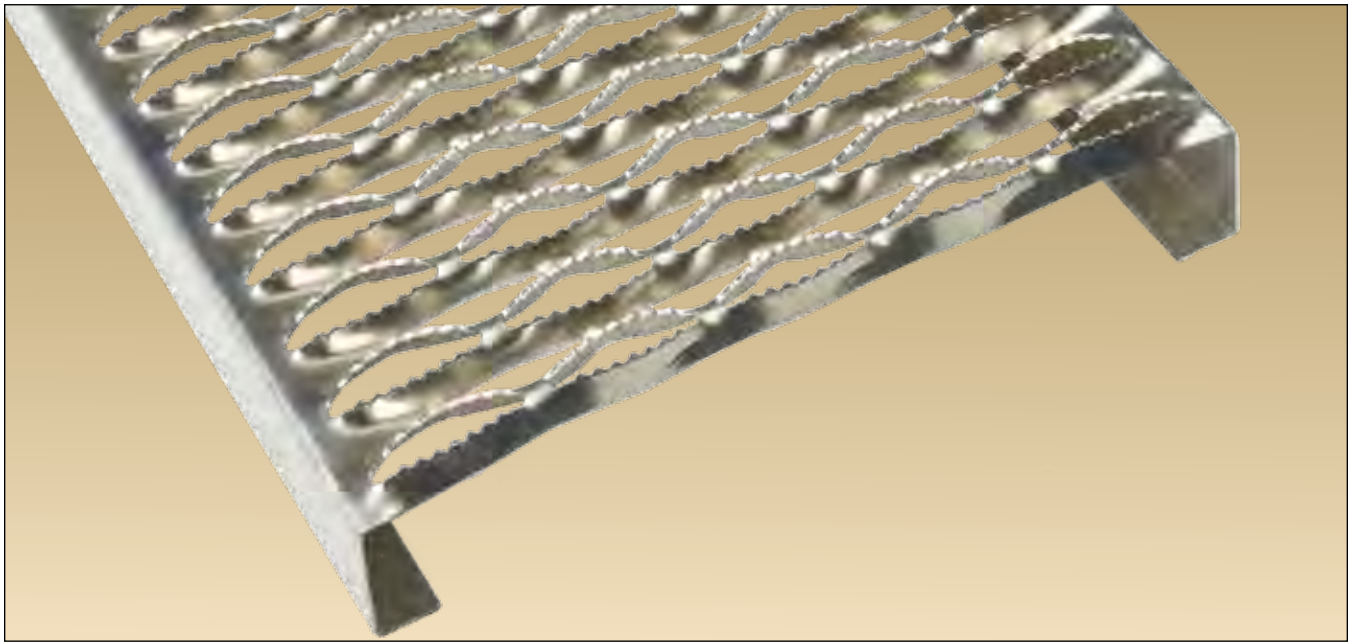

11-3/4" (5 Diamond) Channel Grating shown below. Dimensions will vary depending on channel width. Refer to the Accurate Screen Grating Catalogue for all available widths and dimensions.

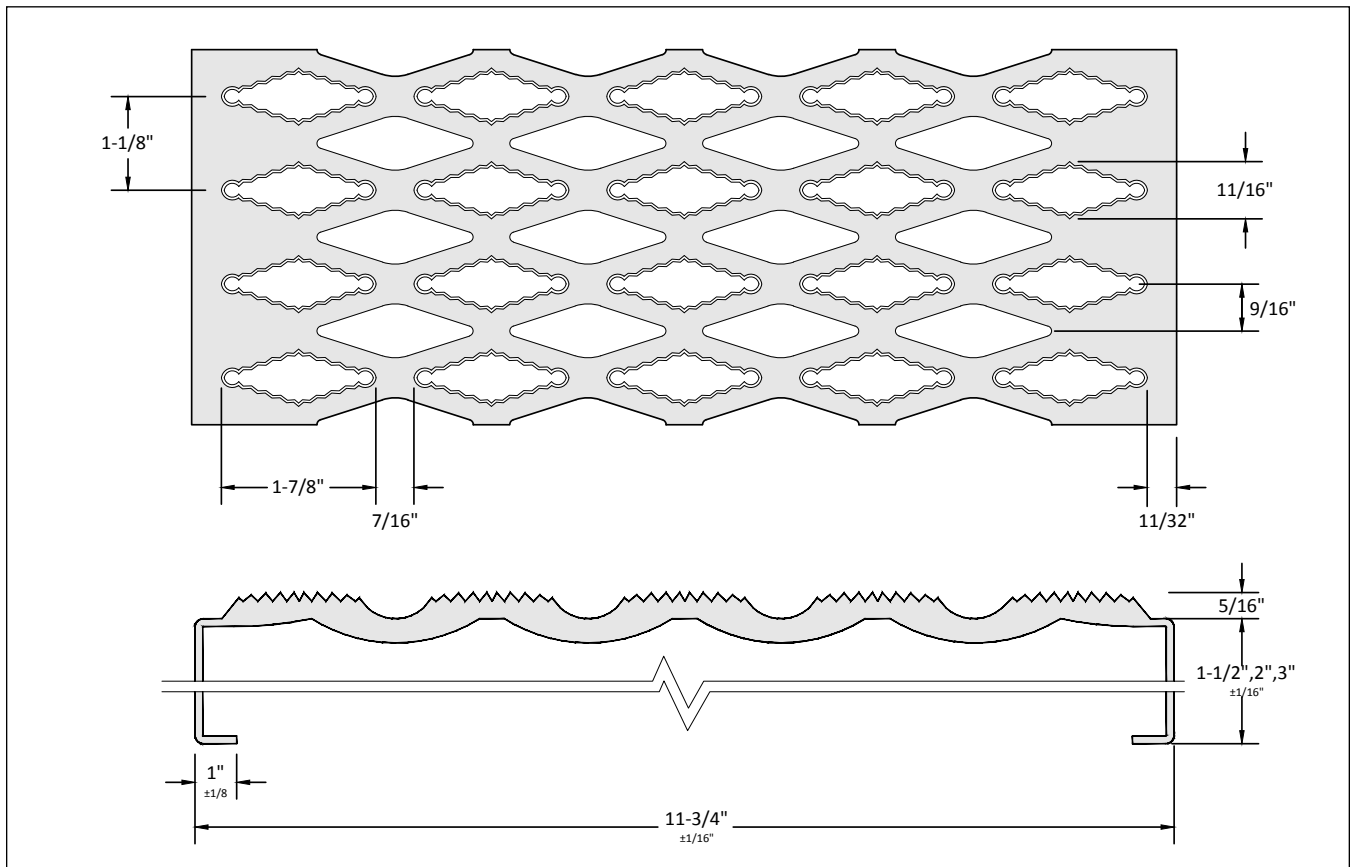

Diamond Channel Grating

ACCEPTABLE LOADING FOR CLEAR SPAN: UNIFORM/CONCENTRATED (LBS)

WIDTH	DEPTH	ALLOY	GAUGE	24" SPAN	36" SPAN	48" SPAN	60" SPAN	72" SPAN
4-3/4"	1.5"	Galv./Steel	14ga	1516/600	674/400	379/300	243/240 NR	168/200 NR
			12ga	1790/708	798/474	451/357	290/287	203/241 NR
	2.0"	Galv./Steel	14ga	2236/885	994/590	559/443	358/354	248/295
			12ga	2255/892	1005/597	567/449	365/361	255/303
		Alum.	0.080"	1398/553	622/369	350/277	225/222 NR	156/186 NR
			0.125"	2331/978	1097/651	617/489	395/390	275/326
		304ss	14ga	1730/685	772/458	436/345	281/278	196/233
316ss	14ga	1730/685	772/458	436/345	281/278	196/233		
7"	1.5"	Galv./Steel	14ga	766/447	343/300	194/227	126/183 NR	92/159 NR
			12ga	1304/761	582/509	329/384	212/309	148/259 NR
	2.0"	Galv./Steel	14ga	1374/802	613/536	347/404	223/326	156/273 NR
			12ga	1710/997	762/667	430/502	277/404	194/339
		Alum.	0.080"	975/568	434/380	244/285	157/228 NR	109/191 NR
			0.125"	1514/963	734/642	414/481	264/386	184/321 NR
		304ss	14ga	1819/1061	811/710	458/534	295/430	206/361 NR
		316ss	14ga	1819/1061	811/710	458/534	295/430	206/361 NR
9-1/2"	1.5"	Galv./Steel	14ga	779/617	346/411	195/309	125/247 NR	87/206 NR
			12ga	988/782	441/524	249/395	161/318	113/268 NR
	2.0"	Galv./Steel	14ga	1063/841	474/563	268/425	173/342	121/288 NR
			12ga	1382/1094	616/732	348/551	224/443	157/372
		Alum.	0.080"	800/633	356/422	200/317 NR	128/253 NR	89/211 NR
			0.125"	1116/927	565/671	318/503	204/403	140/335 NR
		304ss	16ga	750/455	330/398	186/299	120/239 NR	82/199 NR
			14ga	1540/915	687/816	388/614	250/494	175/415 NR
	316ss	14ga	1540/915	687/816	388/614	250/494	175/415 NR	
	3.0"	Galv.	12ga	2270/1355	1009/1355	567/1098	444/878	308/732
	11-3/4"	1.5"	Galv./Steel	14ga	543/493	243/357	138/270	89/219 NR
12ga				842/815	376/552	212/415	137/334 NR	95/280 NR
2.0"		Galv./Steel	14ga	895/493	400/493	226/443	146/357	102/299 NR
			12ga	1243/815	554/814	313/613	200/491	139/409 NR
		Alum.	0.080"	715/362	319/362	179/350	114/280 NR	79/233 NR
			0.125"	904/753	451/662	255/495	162/397	113/330 NR
		304ss	16ga	606/376	296/376	167/333	107/266 NR	74/222 NR
			14ga	1276/899	565/830	319/625	206/503 NR	144/423 NR
316ss		14ga	1276/899	565/830	319/625	206/503 NR	144/423 NR	
3.0"		Galv.	12ga	1666/815	946/815	532/815	341/815	237/695
18-3/4"	1.5"	Galv./Steel	14ga	411/555	182/428	103/321 NR	66/257 NR	46/214 NR
			12ga	553/818	246/576	138/432	89/346 NR	61/288 NR
	2.0"	Galv./Steel	14ga	606/555	269/555	152/474	97/379 NR	67/316 NR
			12ga	825/818	367/818	206/644	132/516 NR	92/430 NR
	Alum.	0.100"	514/537	229/537	129/402 NR	83/323 NR	58/269 nr	
	3.0"	Galv.	12ga	1047/818	654/818	368/818	235/818	163/766
24"	1.5"	Galv./Steel	14ga	367/571	163/489	92/367 NR	59/293 NR	41/245 NR
			12ga	496/861	220/661	124/496 NR	79/397 NR	55/332 NR
	2.0"	Galv./Steel	14ga	539/571	240/571	135/539	86/431 NR	60/359 NR
			12ga	738/861	328/861	185/738	118/590 NR	82/492 NR
	3.0"	Galv.	12ga	861/861	580/861	326/861	209/861	145/861
24"	5.0"	Galv.	12ga	475/900	475/900	475/900	340/850	236/709

NR = Not Recommended

Loads and deflections are theoretical and based on static loading.

Round Channel Grating

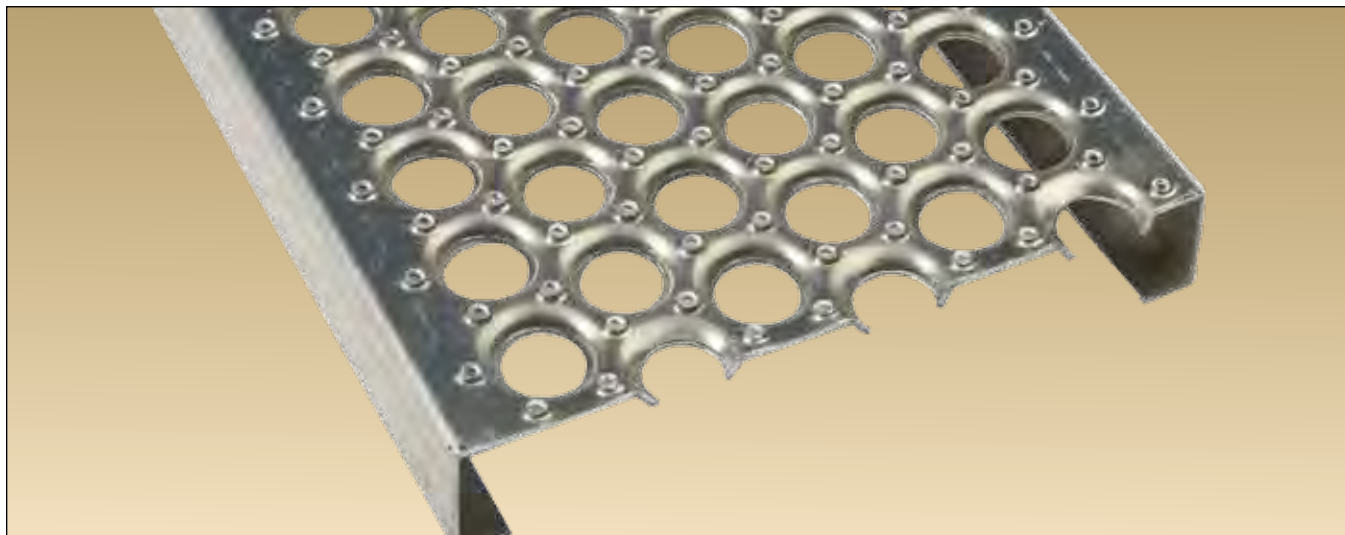

12" (6 Hole) Channel Grating shown below. Dimensions will vary depending on channel width. Refer to the Accurate Screen Grating Catalogue for all available widths and dimensions.

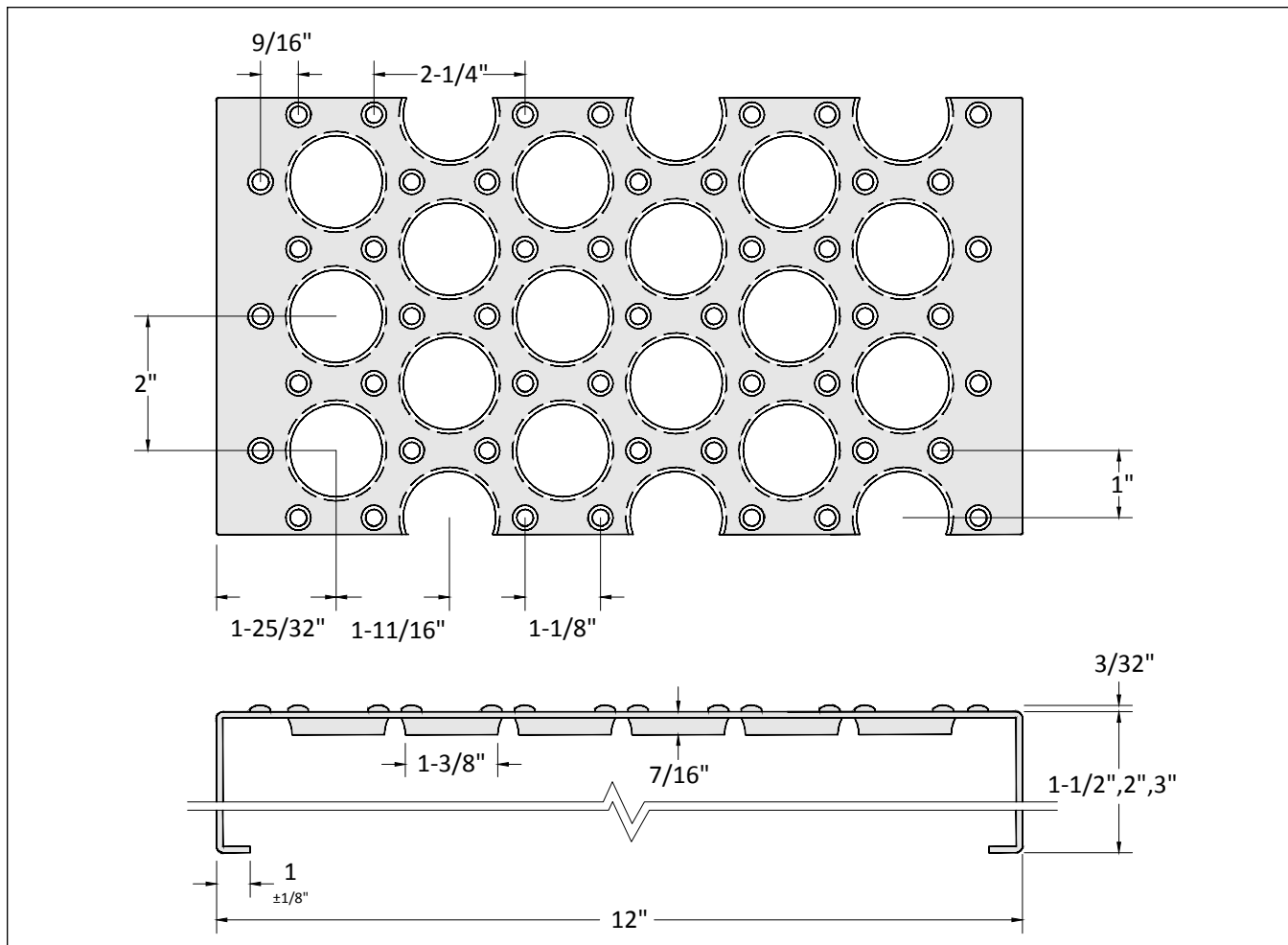

Round Channel Grating

ACCEPTABLE LOADING FOR CLEAR SPAN: UNIFORM/CONCENTRATED (LBS)

WIDTH	DEPTH	ALLOY	GAUGE	24" SPAN	36" SPAN	48" SPAN	60" SPAN	72" SPAN
5"	1.5"	Galv./Steel	13ga	1947/811	868/542	490/408	315/328	220/275
			11ga	2832/1172	1259/781	708/586	453/469	315/391
	2.0"	Galv./Steel	13ga	2943/973	1311/819	739/616	475/495	331/414
			11ga	4278/1738	1901/1159	1070/869	685/695	475/579
		Alum.	0.125ga	2479/1033	1102/689	620/516	397/413	275/344 NR
		304ss	14ga	3295/1373	1464/915	824/686	527/549	366/458
316ss	14ga	3295/1373	1464/915	824/686	527/549	366/458		
7"	1.5"	Galv./Steel	13ga	1489/793	664/581	375/437	241/352	169/295
			11ga	1921/1098	856/749	483/564	310/453	217/379
	2.0"	Galv./Steel	13ga	2229/793	993/793	560/654	360/525	251/440
			11ga	2995/1098	1333/1098	752/877	483/704	336/589
		Alum.	0.125ga	1984/1157	882/771	496/579	317/463	220/386
		304ss	14ga	2147/1253	955/835	537/626	344/501	239/418
	316ss	14ga	2147/1253	955/835	537/626	344/501	239/418	
	3.0"	Galv.	11ga	3765/1098	2503/1098	1410/1098	904/1098	629/1098
10"	1.5"	Galv./Steel	13ga	1128/625	501/625	282/470	181/379	125/313
			11ga	1343/861	599/749	338/564	218/453	152/380
	2.0"	Galv./Steel	13ga	1500/625	748/625	422/625	272/566	190/474
			11ga	2067/861	975/861	550/861	353/735	245/612
		Alum.	0.125ga	1278/533	605/533	341/533	218/455	152/380
		304ss	14ga	946/394	529/394	298/394	190/394	133/331
	316ss	14ga	946/394	529/394	298/394	190/394	133/331	
	3.0"	Galv.	11ga	2067/861	1816/861	1021/861	654/861	454/861
12"	1.5"	Galv./Steel	13ga	991/866	442/663	250/500	161/403	113/338
			11ga	1118/1118	499/748	282/564	182/454	127/381
	2.0"	Galv./Steel	13ga	1457/866	649/866	367/733	236/590	165/494
			11ga	1875/1362	835/1253	471/942	303/757	211/634
		Alum.	0.125ga	1245/839	554/831	312/624	200/500	139/417
		304ss	14ga	871/435	417/435	236/435	152/434	106/361
	316ss	14ga	871/435	417/435	236/435	152/434	106/361	
	3.0"	Galv.	11ga	2725/1362	1647/1362	927/1362	565/1362	414/1243
18"	1.5"	Galv./Steel	13ga	641/480	304/480	174/480	112/421	79/355
			11ga	752/1116	336/755	190/570	123/460	86/387
	2.0"	Galv./Steel	13ga	641/480	460/480	260/480	168/480	117/480
			11ga	1207/1116	538/1116	304/911	195/733	137/615
	Alum.	0.125ga	792/594	360/594	203/594	130/567	91/472	
	3.0"	Galv.	11ga	1488/1116	1153/1116	649/1116	415/1116	288/1116
24"	2.0"	Galv./Steel	11ga	524/524	467/524	264/524	170/524	119/524
	3.0"	Galv./Steel	11ga	467/524	524/524	473/524	304/524	212/524
30"	2.0"	Galv./Steel	11ga	275/343	275/343	231/343	148/343	103/343
	3.0"	Galv./Steel	11ga	275/343	275/343	275/343	219/343	152/343
24"	5.0"	Galv.	11ga	657/657	657/657	657/657	657/657	657/657
30"	5.0"	Galv.	11ga	384/480	384/480	384/480	384/480	384/480
36"	5.0"	Galv.	11ga	185/273	185/273	185/273	185/273	185/273

NR = Not Recommended

Loads and deflections are theoretical and based on static loading.

Walkway Channel Grating

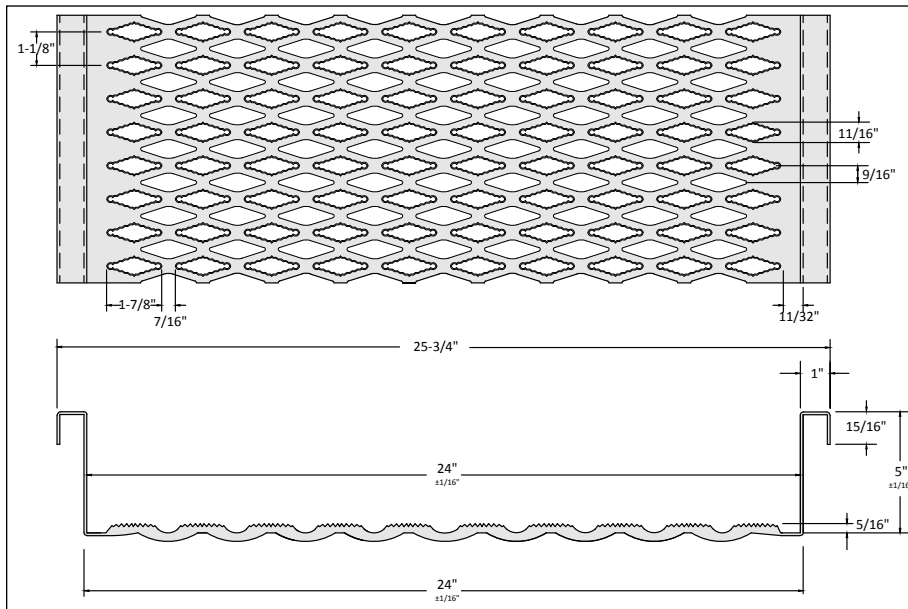
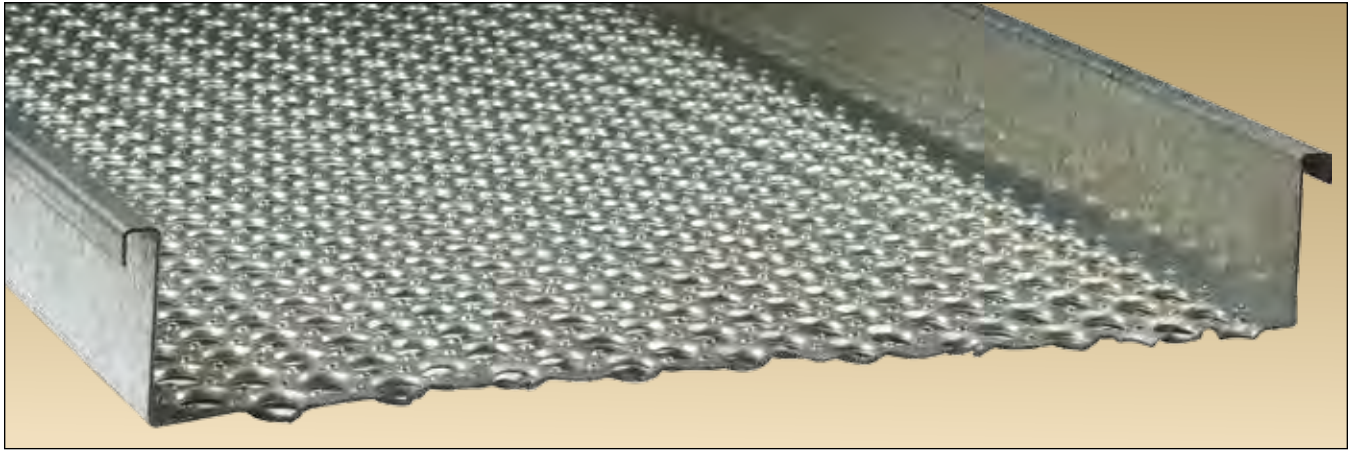

24" WIDE (10 Diamond) Walkway Grating drawing shown.

Available in 24" widths.
Refer to Diamond Channel
dimension and load chart
(Page 45) for technical
specifications, available
widths and alloys.

36" WIDE (9 Hole) Walkway Grating drawing shown.

Available in 24 to 36" widths.
Refer to Round Channel
dimension and load chart
(Page 47) for technical
specifications, available
widths and alloys.

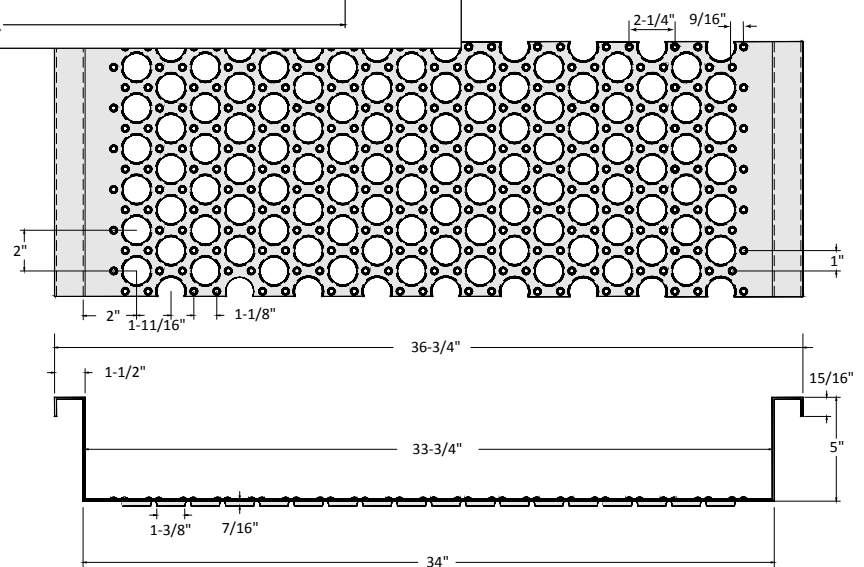

Dimple Tread Channel Grating

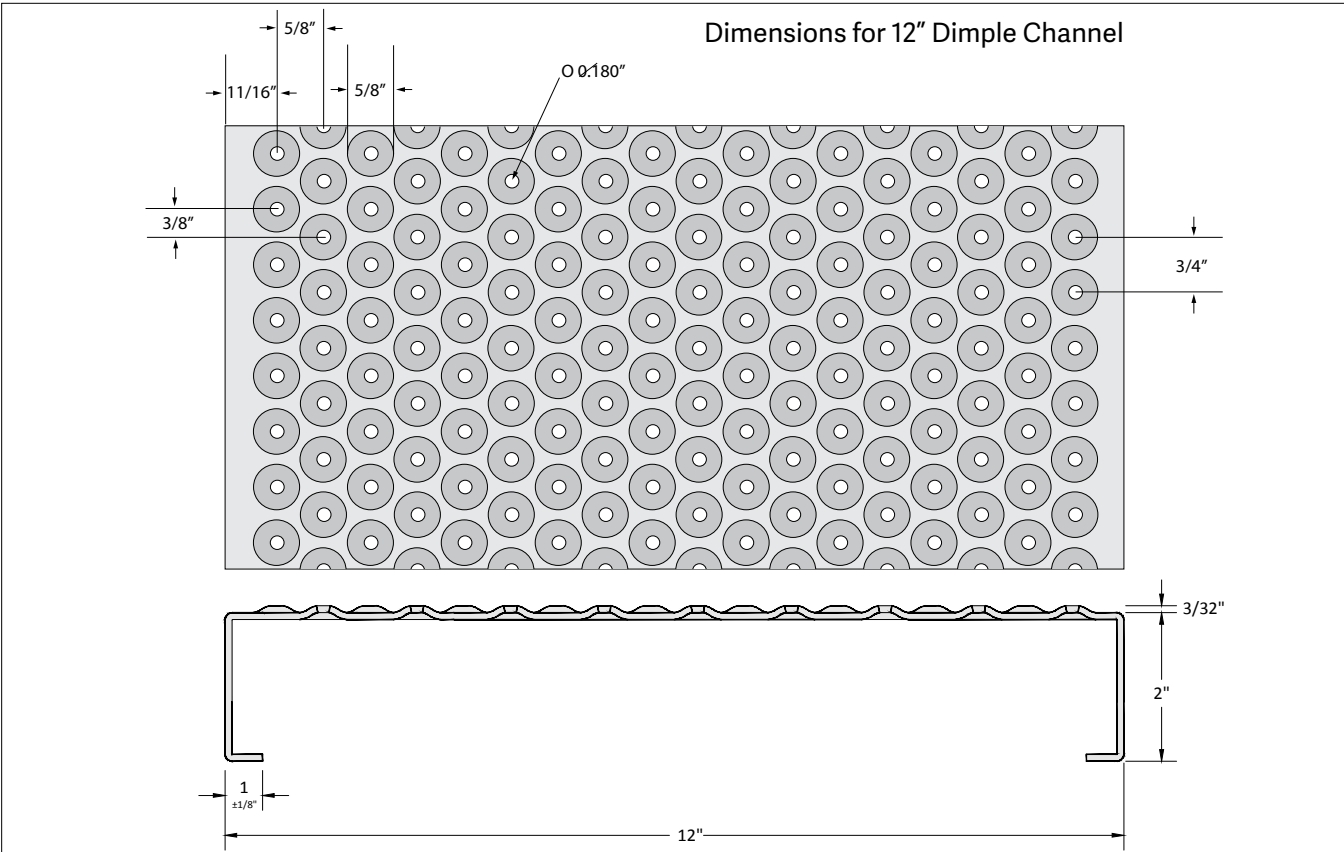
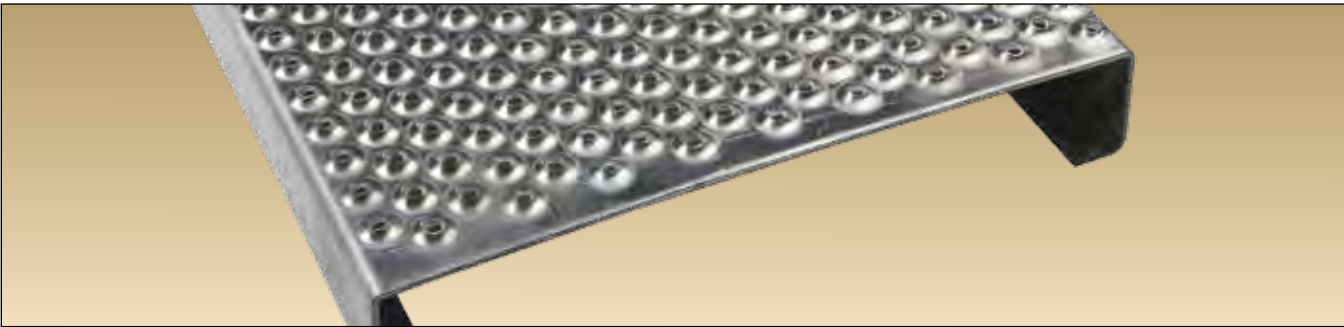

ACCEPTABLE LOADING FOR CLEAR SPAN: UNIFORM/CONCENTRATED (LBS)								
WIDTH	DEPTH	ALLOY	GAUGE	24" SPAN	36" SPAN	48" SPAN	60" SPAN	72" SPAN
7"	2.0"	Galv.	11ga	2084/1405	1235/1061	651/746	400/689	322/527
		Alum.	0.125ga	727/490	431/370	227/260	139/173	112/116
10"	2.0"	Galv.	11ga	1605/1554	951/1174	502/826	308/551	248/367
		Alum.	0.125ga	560/542	332/409	175/288	107/192	86/128
12"	2.0"	Galv.	11ga	1395/1624	827/1227	436/863	268/575	215/384
		Alum.	0.125ga	487/566	288/428	152/301	93/201	75/134

Loads and deflections are theoretical and based on static loading.

Grating Treads - Diamond Channel Tread

DIAMOND CHANNEL GRATING END PLATE DETAIL

- 3MM/11GA. GALVANIZED
- FOR USE WITH 1-1/2" AND 2" HEIGHTS

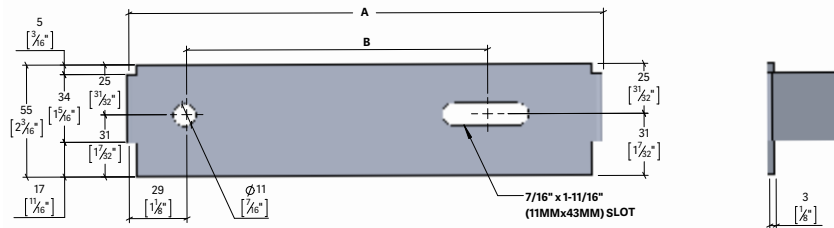

GALVANIZED DIAMOND CHANNEL GRATING					
CHANNEL WIDTH		DIMENSION 'A'		DIMENSION 'B'	
METRIC (MM)	IMPERIAL (INCHES)	METRIC (MM)	IMPERIAL (INCHES)	METRIC (MM)	IMPERIAL (INCHES)
120	4 3/4	114	4 1/2	41	1 5/8
178	7	171	6 3/4	89	3 1/2
241	9 1/2	235	9 1/4	149	5 7/8
298	11 3/4	292	11 1/2	206	8 1/8

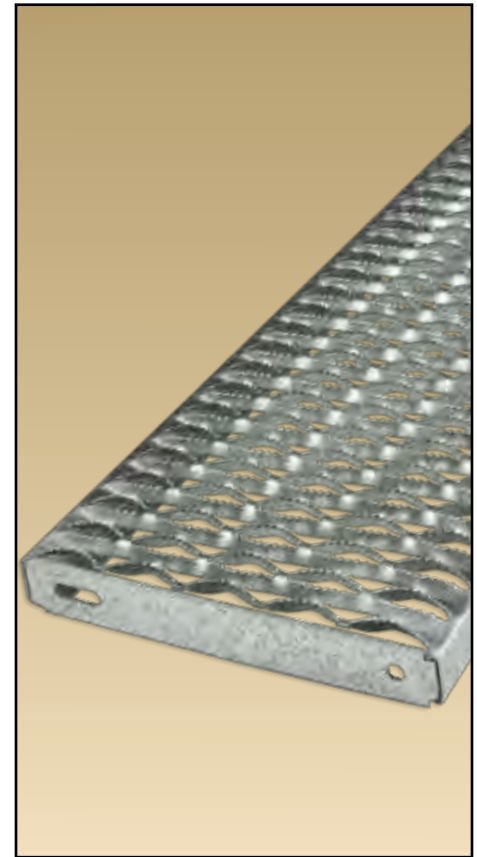

DIAMOND CHANNEL STAIR TREAD - LOAD TABLES - GALV. STEEL

GAUGE	Span	Height	4-3/4"		7"		9-1/2"		11-3/4"									
			U	C	U	C	U	C	U	C								
24"	1.5"		1191	472	1576	624	761	443	1006	587	549	435	750	595	434	425	575	563
	2"		1978	783	2513	995	1262	737	1604	936	911	604	1158	917	721	573	916	897
30"	1.5"		764	378	1011	500	488	356	645	470	353	349	481	476	278	342	369	452
	2"		1268	611	1611	797	810	590	1029	750	584	578	742	734	463	566	587	719
36"	1.5"		532	315	703	418	340	30	450	393	245	300	335	398	194	300	258	378
	2"		882	524	1121	665	563	492	716	626	407	483	517	614	322	473	409	601
48"	2"		498	394	633	501	318	372	404	472	230	364	292	463	182	356	232	454

DIAMOND CHANNEL STAIR TREAD - LOAD TABLES - ALUMINUM & 304 STAINLESS

GAUGE	Span	Height	4-3/4"		7"		9-1/2"		11-3/4"					
			Aluminum .080"	Stainless 304	Aluminum .080"	Stainless 304	Aluminum .080"	Stainless 304	Aluminum .080"	Stainless 304				
24"	2"		1328	526	862	503	607	481	610	483	396	388	394	386
30"	2"		850	420	551	402	388	392	390	387	253	388	252	381
36"	2"		590	350	383	335	270	327	271	323	176	321	175	319
48"	2"		332	253	215	252	152	245	152	244	99	241	98	241

Loads and deflections are theoretical and based on static loading.

Grating Treads - Round Channel Tread

ROUND CHANNEL GRATING END PLATE DETAIL

- 3MM/11GA. GALVANIZED
- FOR USE WITH 1-1/2" AND 2" HEIGHTS

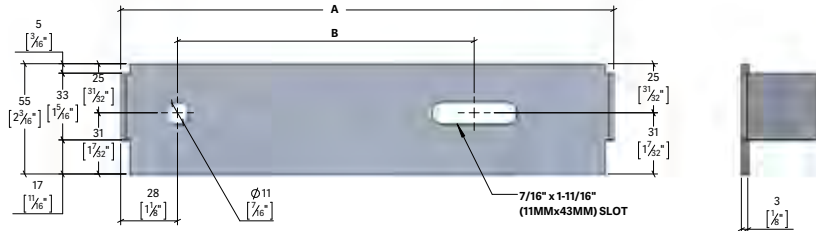

GALVANIZED ROUND CHANNEL GRATING					
CHANNEL WIDTH		DIMENSION 'A'		DIMENSION 'B'	
METRIC (MM)	IMPERIAL (INCHES)	METRIC (MM)	IMPERIAL (INCHES)	METRIC (MM)	IMPERIAL (INCHES)
127	5	121	4 3/4	41	1 5/8
178	7	171	6 3/4	89	3 1/2
254	10	248	9 3/4	149	5 7/8
305	12	298	11 3/4	206	8 1/8

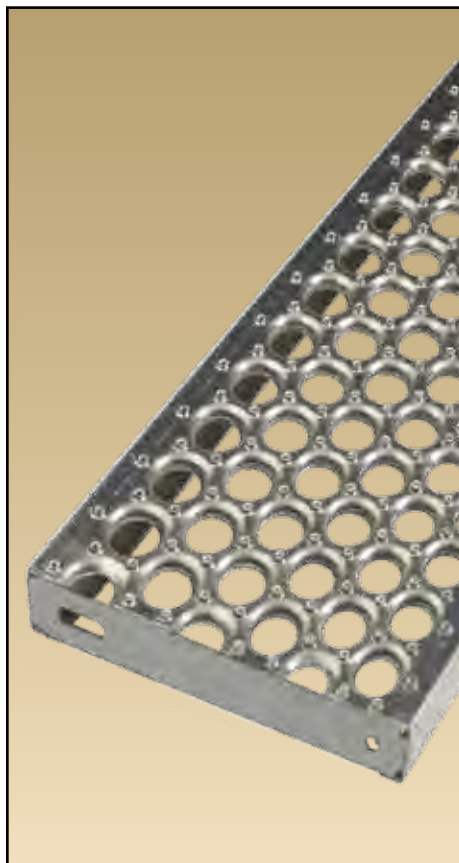

ROUND CHANNEL STAIR TREAD - LOAD TABLES - GALV. STEEL

GAUGE	Span	Height	5"				7"				10"				12"			
			U	C	U	C	U	C	U	C	U	C	U	C	U	C		
24"	1.5"	1947	811	2832	1172	1489	793	1921	1098	1128	625	1343	861	991	866	1118	1118	
	2"	2943	973	4278	1738	2229	793	2995	1098	1500	625	2067	861	1457	866	1875	1362	
36"	1.5"	868	542	1259	781	664	581	856	749	501	625	338	564	442	663	499	748	
	2"	1311	819	1901	1159	993	793	1333	1098	748	625	975	861	649	866	835	1253	
48"	2"	739	616	1070	869	560	654	752	877	422	625	550	861	367	733	471	932	

ROUND CHANNEL STAIR TREAD - LOAD TABLES - ALUMINUM & 304 STAINLESS

GAUGE	Span	Height	5"		7"		10"		12"				
			Aluminum .125ga	Aluminum .125ga	Aluminum .125ga	Stainless 304	Aluminum .080"	Stainless 304					
U	C	U	C	U	C	U	C	U	C				
24"	2"	2479	1033	1984	1157	1278	533	946	394	1245	839	871	435
36"	2"	1102	689	882	771	605	533	529	394	554	831	417	435
48"	2"	620	516	496	579	341	533	298	394	312	624	236	435

Loads and deflections are theoretical and based on static loading.

Ladder Rung

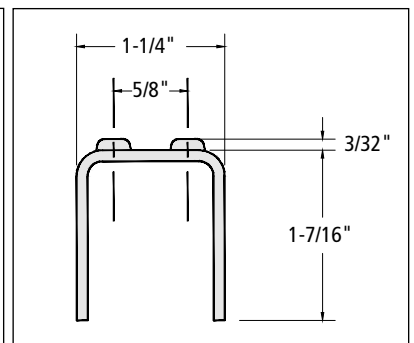
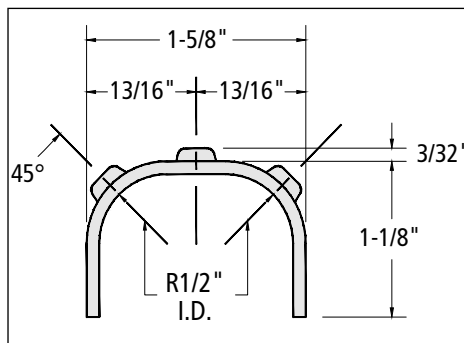
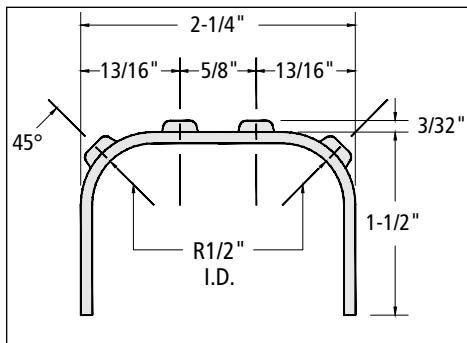
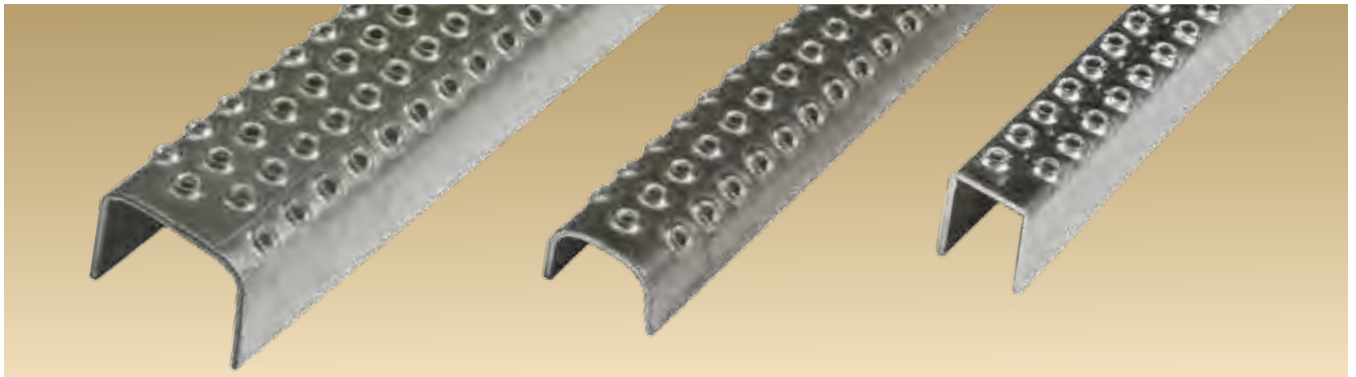

ACCEPTABLE LOADING FOR CLEAR SPAN: UNIFORM/CONCENTRATED (LBS)

TYPE	GAUGE	ALLOY	DEPTH	16" SPAN	18" SPAN	20" SPAN	24" SPAN
2 hole 1-1/4"	13ga	HRPO	1-7/16"	508	451	401	338
	11ga	HRPO	1-7/16"	664	590	531	443
	.125"	Alum	1-7/16"	471	418	377	314
	16ga	304ss	1-7/16"	345	306	276	230
	14ga	316ss	1-7/16"	414	367	331	276
3 hole 1-5/8"	13ga	HRPO	1-1/8"	375	334	300	250
	11ga	HRPO	1-1/8"	474	422	379	316
	.125"	Alum	1-1/8"	337	299	269	224
	16ga	304ss	1-1/8"	260	231	208	NR
	14ga	316ss	1-1/8"	312	277	250	222
4 hole 2-1/4"	13ga	HRPO	1-1/2"	862	766	689	574
	11ga	HRPO	1-1/2"	1138	1012	911	759
	.125"	Alum	1-1/2"	810	720	649	540
	16ga	304ss	1-1/2"	580	516	464	387
	14ga	316ss	1-1/2"	696	619	557	464

Loads and deflections are theoretical and based on static loading.
Ladder rung supplied at 60" lengths. Customs lengths and coping upon request.

ALUMINUM DECKING, CLADDING & NON-SLIP FLOORING

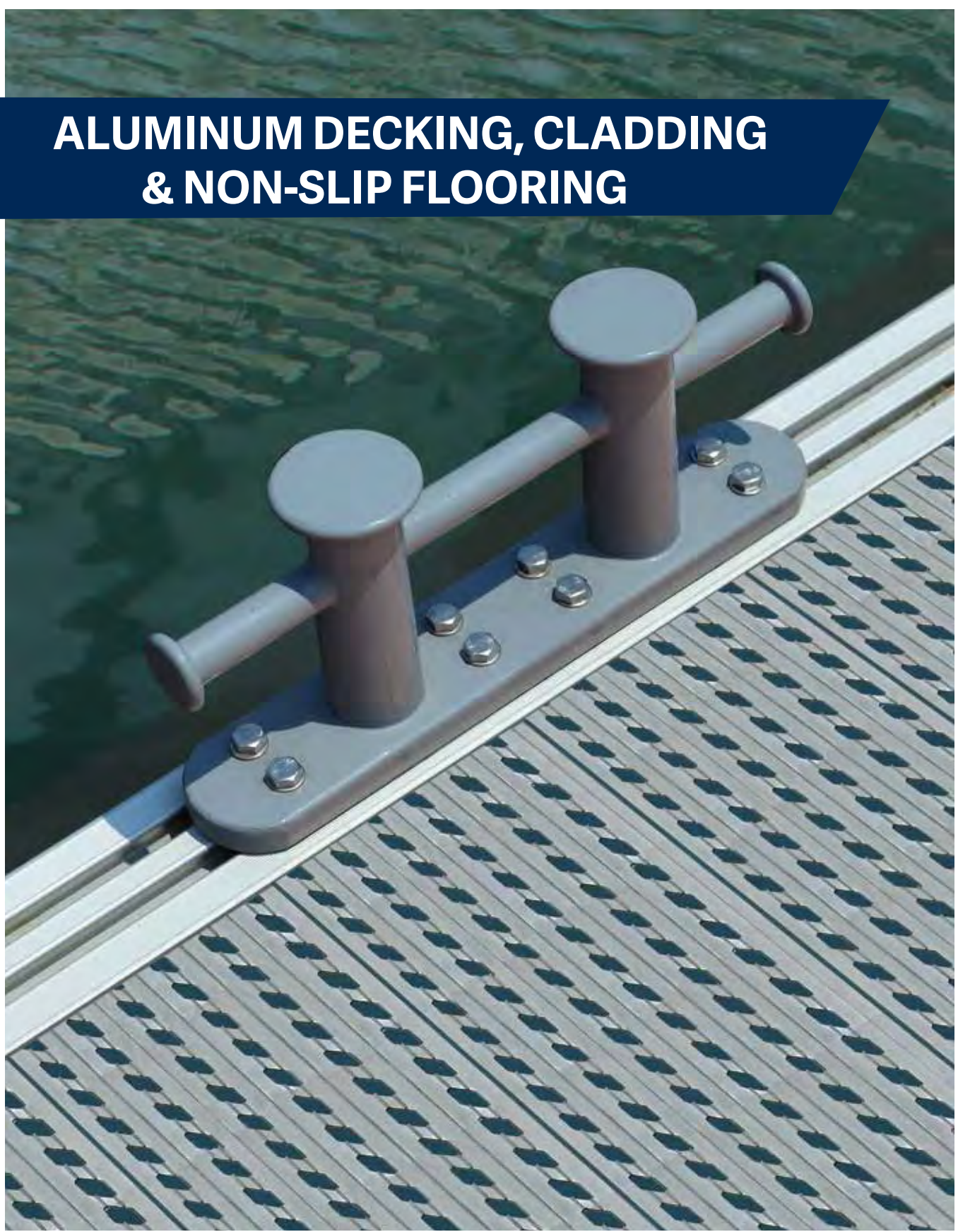

EXTRUDED ALUMINUM DECKING

Open

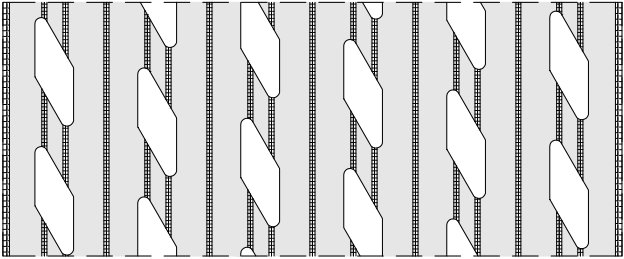

Dovetail Inter-lock required to connect Open and Solid Extruded Aluminum Decking Planks.

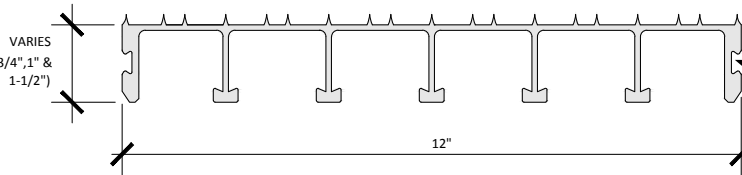

Solid

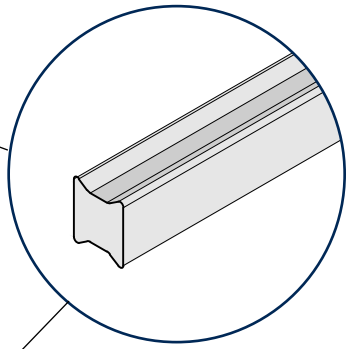
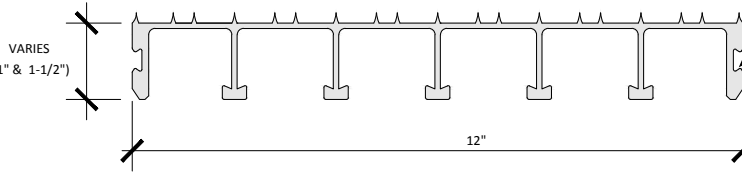
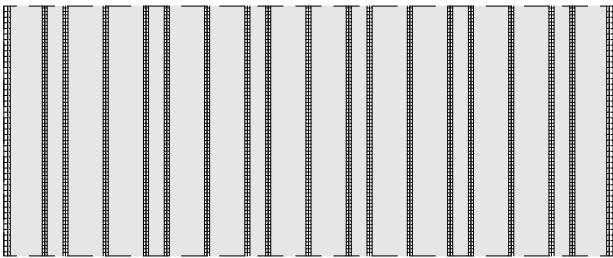

OPEN - ACCEPTABLE LOADING FOR CLEAR SPAN: UNIFORM/CONCENTRATED (LBS)									
WIDTH	DEPTH	SURFACE	ALLOY	24" SPAN	36" SPAN	48" SPAN	60" SPAN	72" SPAN	96" SPAN
6"	1.5"	open	Alum	2992/1496	1330/997	748/748	478/598 NR	332/499 NR	187/374 NR
12"	.75"	open	Alum	803/803	357/535	201/401 NR	128/321 NR		
12"	1.0"	open	Alum	1328/1328	590/885	332/664	212/531 NR	147/442 NR	
12"	1.5"	open	Alum	2612/2612	1161/1741	653/1306	418/1044	290/870 NR	163/653 NR
SOLID - ACCEPTABLE LOADING FOR CLEAR SPAN: UNIFORM/CONCENTRATED (LBS)									
WIDTH	DEPTH	SURFACE	ALLOY	24" SPAN	36" SPAN	48" SPAN	60" SPAN	72" SPAN	96" SPAN
12"	1.0"	solid	Alum	1328/1328	590/885	332/664	212/531 NR	147/442 NR	
12"	1.5"	solid	Alum	2612/2612	1161/1741	653/1306	418/1044	290/870 NR	163/653 NR

Extruded Aluminum Decking available in cut lengths up to 96" and mill stock lengths.

NR = Not Recommended

Loads and deflections are theoretical and based on static loading.

ALUMINUM CLADDING

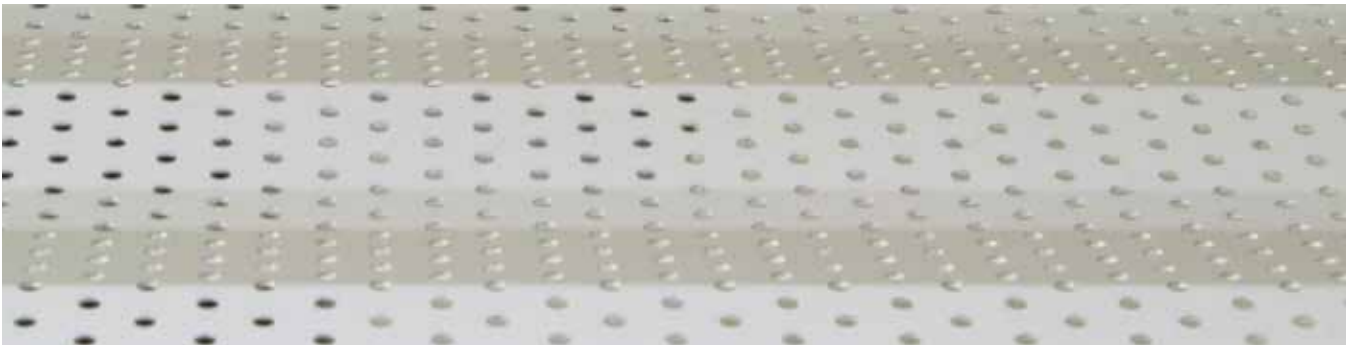

- standard sheet sizes 36" x 96" & 36" x 121"
- available in bare aluminum and industry standard white on one side
- custom sizes including coil available upon request
- for sheet weight and open area calculations visit our website www accuratescreen.ca

Profiled Aluminum provides rigidity which allows the material to be thinner, making jobs with larger continuous span requirements more cost effective.

Although the aluminum utilized in panel applications is available in coil form we stock this material in the standard sheet sizes mentioned above. As a value added service we profile the material when it arrives from the mill in order to deliver quick turn around times and to guarantee product quality.

Non-Perforated	
Code	Description
SA-24 3 x 10	Aluminum Sheet 24GA 36" X 121"
SA-24 3 x 8	Aluminum Sheet 24GA 36" X 96"
SAW-24 3 x 10	White Aluminum Sheet 24GA 36" X 121"
SAW-24 3 x 8	White Aluminum Sheet 24GA 36" X 96"
Perforated	
Code	Description
PA-20-093-33% 3 x 10	Perf 20GA Plain 3/32" rd. 33% o.a. 36" x 121"
PAW-20-093-33% 3 x 10	Perf 20GA White 3/32" rd. 33% o.a. 36" x 121"
PAW-20-125-10% 3 x 10	Perf 20GA White 1/8" rd. 10% o.a. 36" x 121"
PAW-20-125-10% 3 x 8	Perf 20GA White 1/8" rd. 10% o.a. 36" x 96"

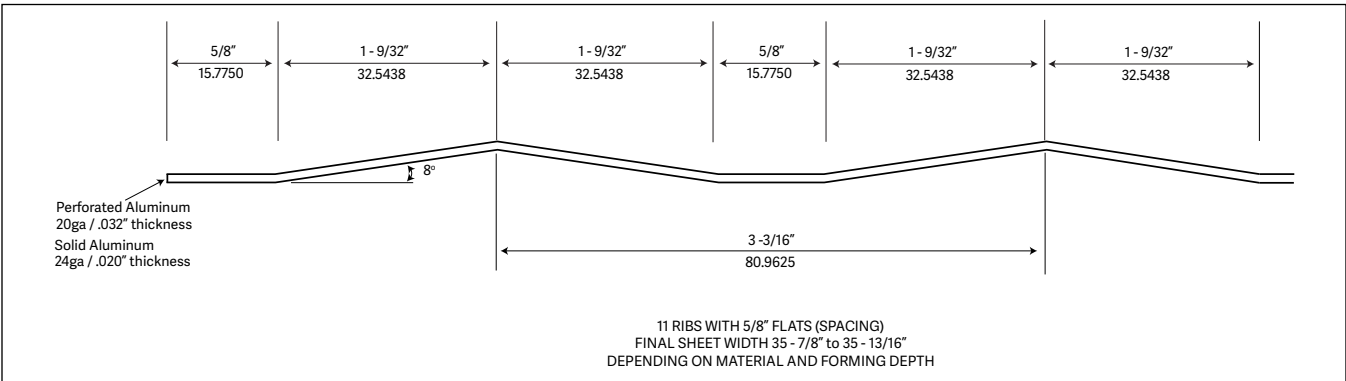

DIMPLE PLATE

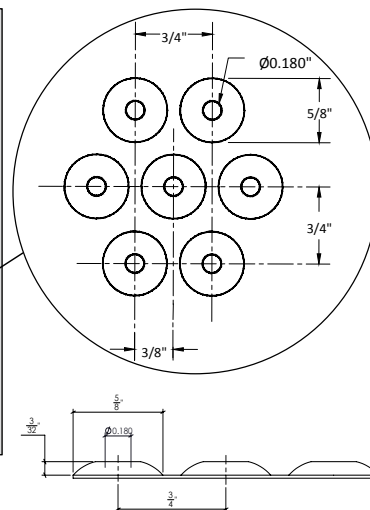
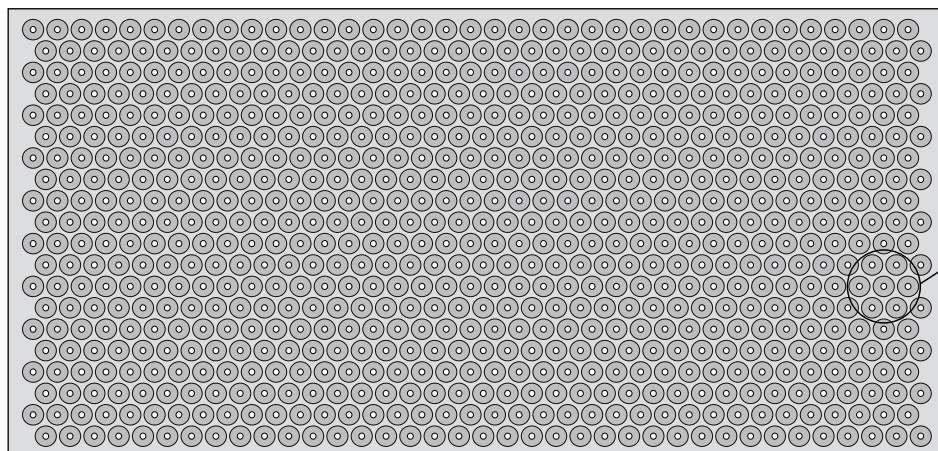
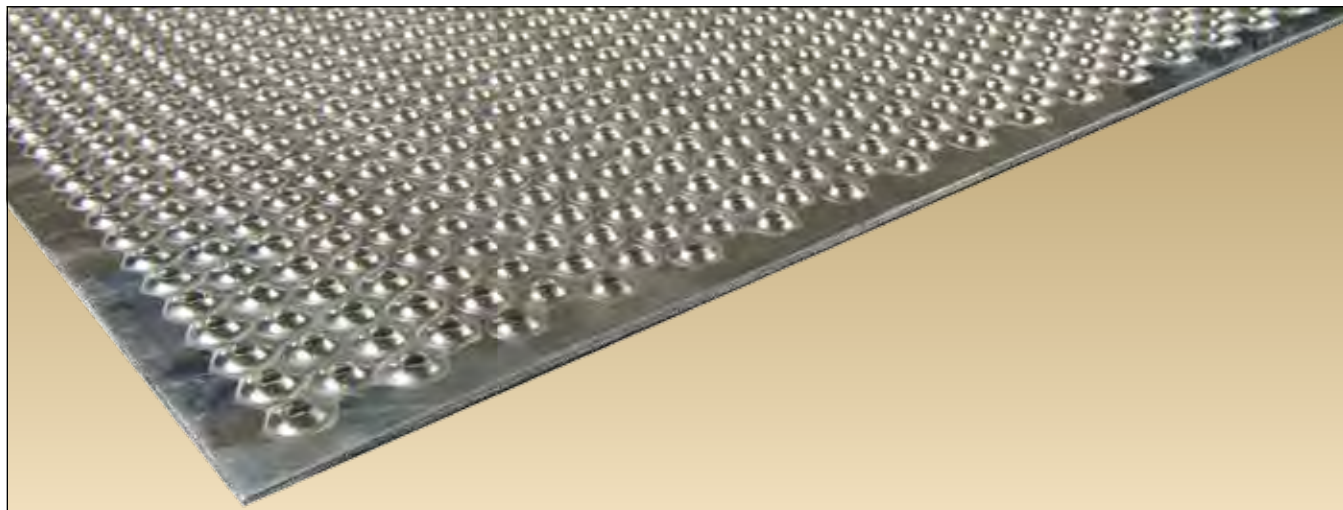

DIMPLE PLATE ALLOY & SHEET DIMENSIONS

ALLOY	GAUGE	WIDTH	LENGTH
Alum	8ga (.125)	36"	120"
Alum	8ga (.125)	48"	120"
CR Steel	11ga (.112)	36"	120"
CR Steel	13ga (.090)	36"	120"
CR Steel	14ga (.075)	48"	96"
Galv	11ga (.124)	36"	120"
Galv	13ga (.094)	36"	120"
304 ss	16ga (.063)	48"	120"

X-DECK

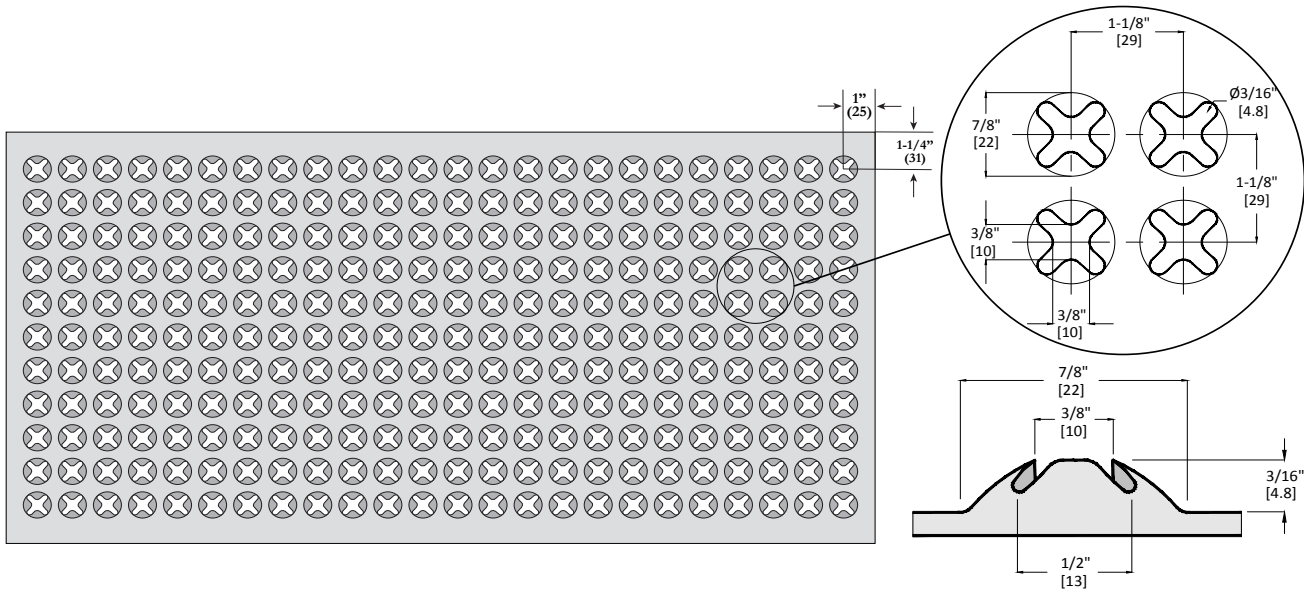
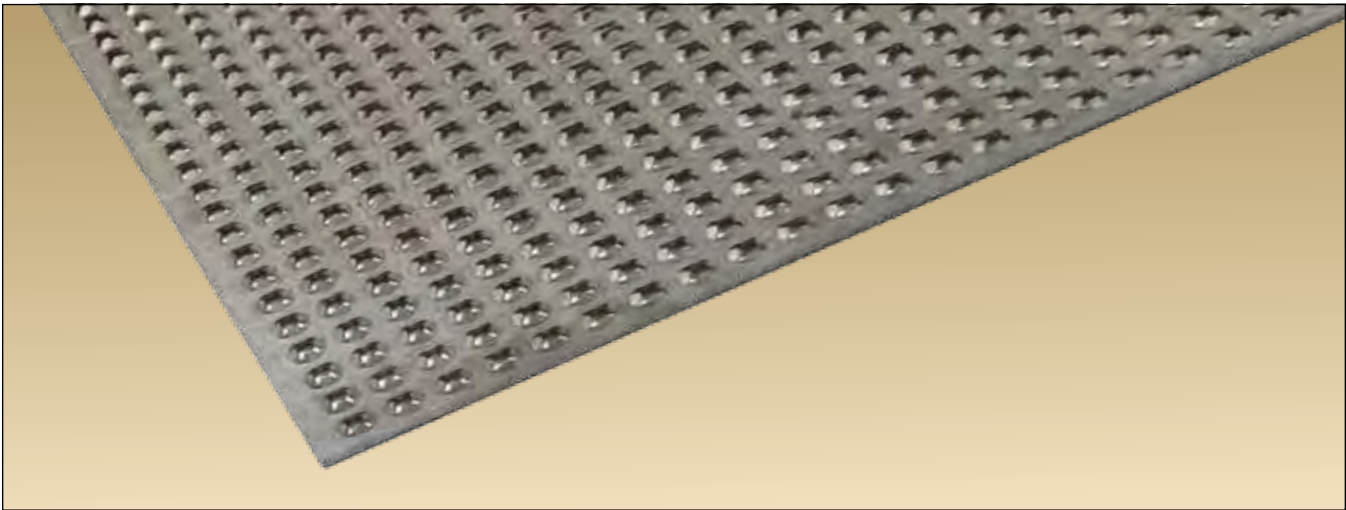

X-DECK ALLOY & SHEET DIMENSIONS			
WIDTH	LENGTH	ALLOY	GAUGE
48"	120"	CR Steel	11ga

FIBREGLASS PLATE

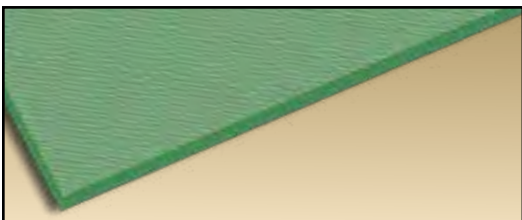

FIBREGLASS PLATE SHEET DIMENSIONS			
WIDTH	LENGTH	THICKNESS	SURFACE
48"	144"	5/8"	Smooth or Grit

TIE WIRE, STEEL BANDING & FASTENERS

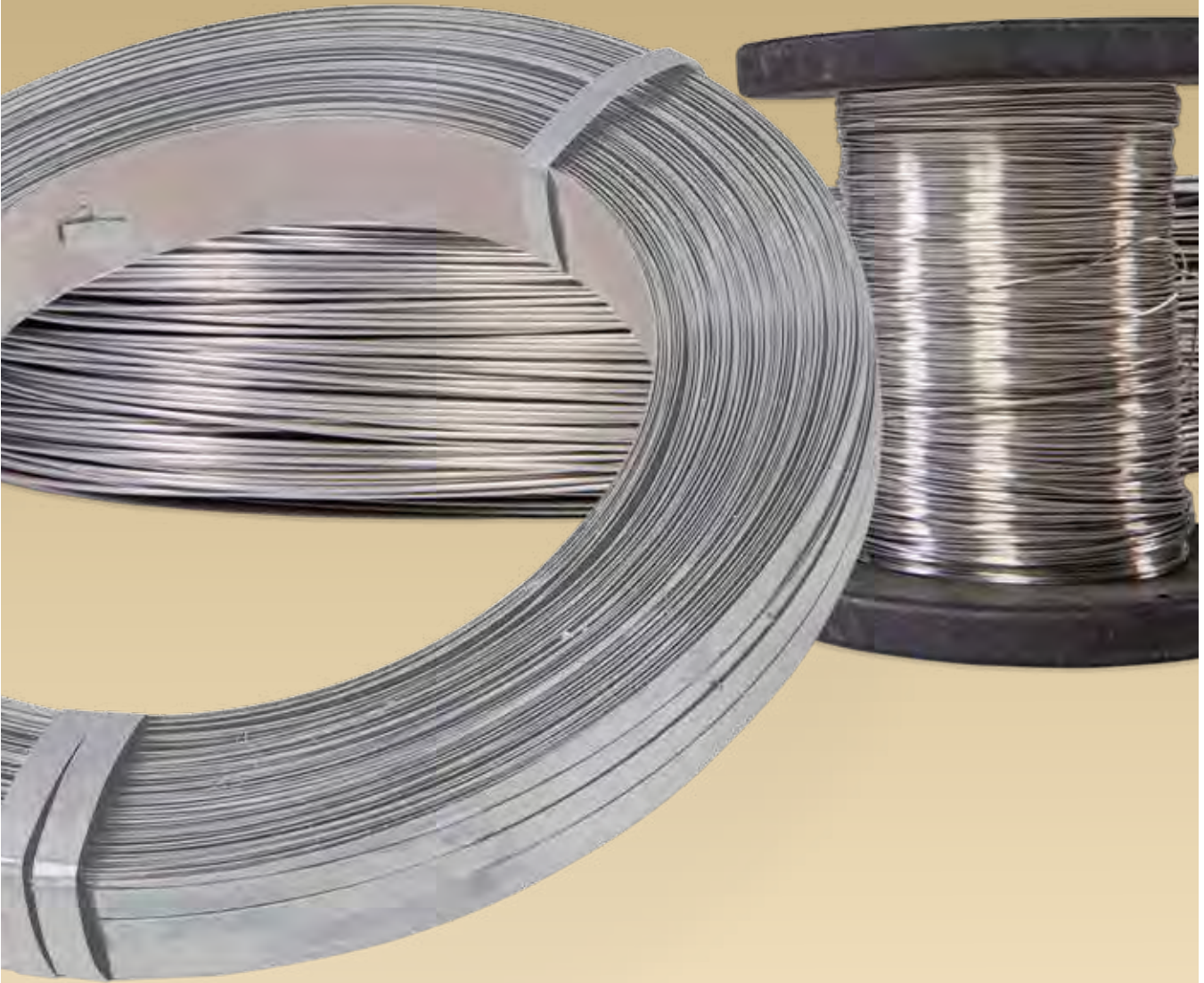

TIE WIRE & BANDING



TIE WIRE

1 LB. Spools

Wire Diameter	Alloy	Feet per Spool
25ga (0.020")	304ss	774
21ga (0.032")	304ss	366
19ga (0.041")	304ss	223
18ga (0.047")	304ss	169
17ga (0.054")	304ss	128
16ga (0.063")	304ss	94

5 LB. Spools

18ga (0.316")	304ss	845
25ga (0.020")	316ss	3870
21ga (0.032")	316ss	1830
19ga (0.041")	316ss	1115
16ga (0.063")	316ss	470

25 LB. Coils

18ga (0.047")	304ss	4225
16ga (0.063")	304ss	2350
14ga (0.080")	304ss	1450

STEEL BANDING

SIZE	Alloy	AVAILABILITY
0.5" x .015"	304ss	28lb. boxes or 85lb. coils
0.5" x 0.20"	304ss	28lb. boxes or 85lb. coils
0.75" x .020"	304ss	28lb. boxes or 85lb. coils

FASTENERS

Bar Grating Clips

DM CLIP ASSEMBLY

STANDARD D-CLIP

304SS INNER HEXAGONAL
FINE THREAD 5/16" Ø X 2-1/2"

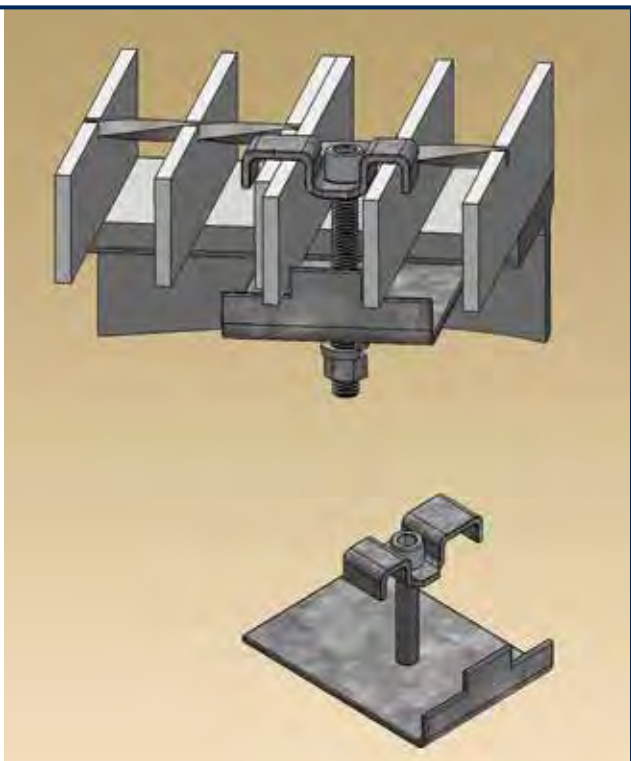
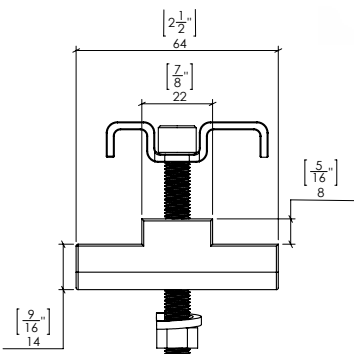
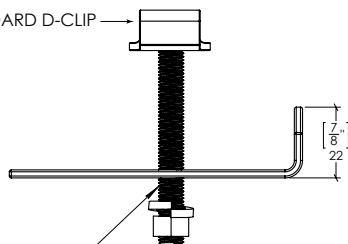

G CLIP ASSEMBLY

Our standard G-clip assembly is limited to 1-1/4" thick grating or less. For thicker grating a long bolt is required.

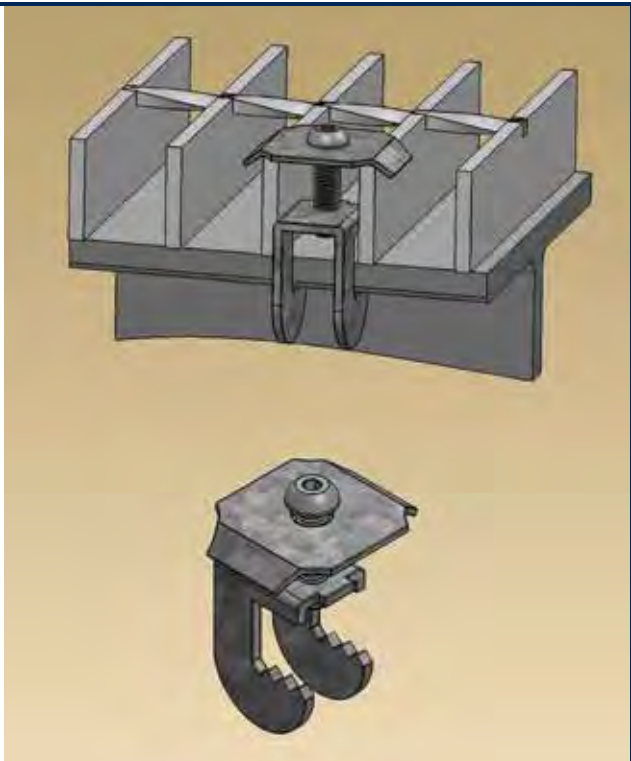
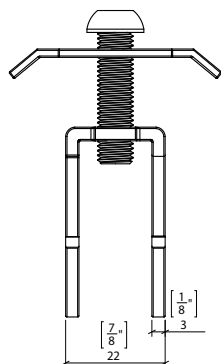
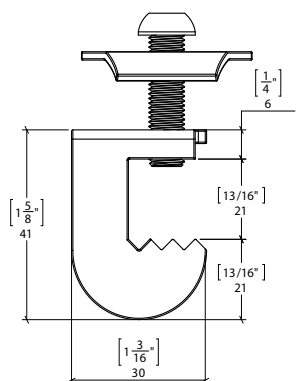

FASTENERS

Bar Grating Clips

ONE SIDED G CLIP ASSEMBLY

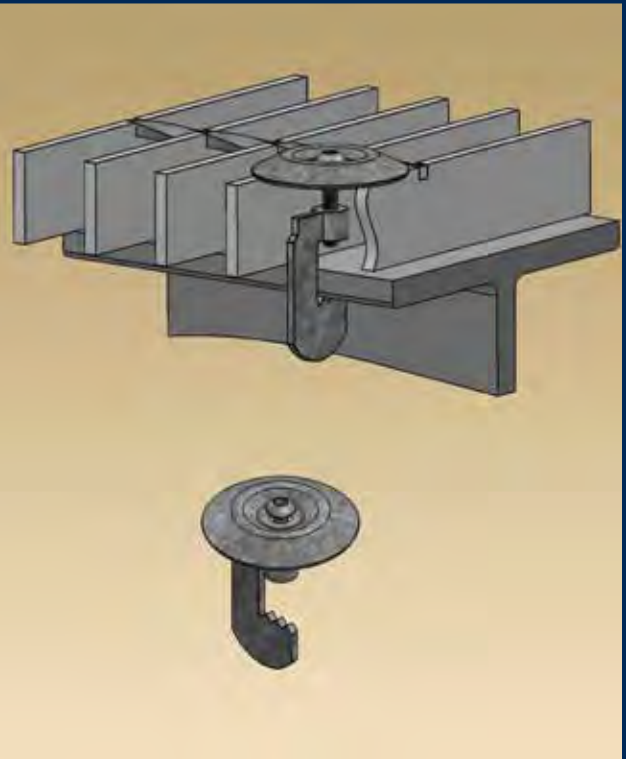
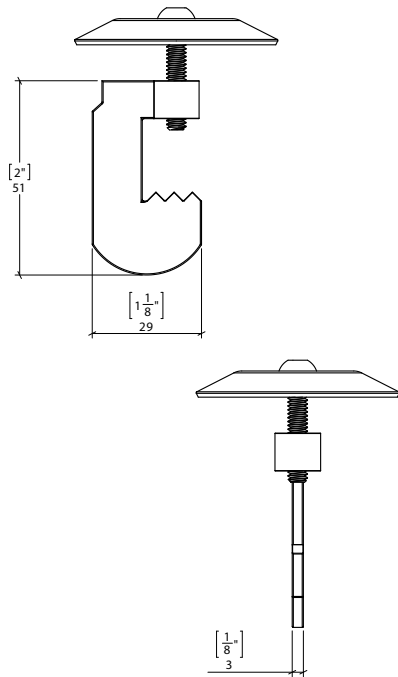

STEP CLIP ASSEMBLY

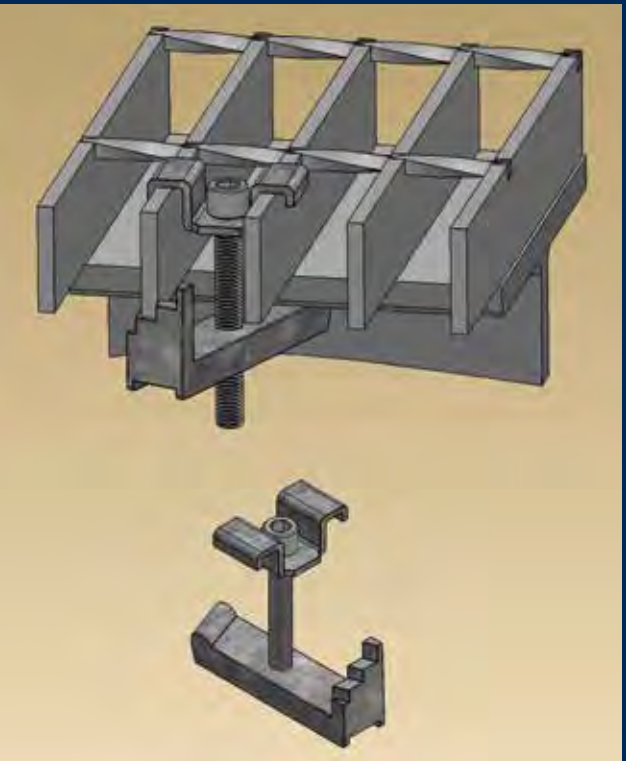
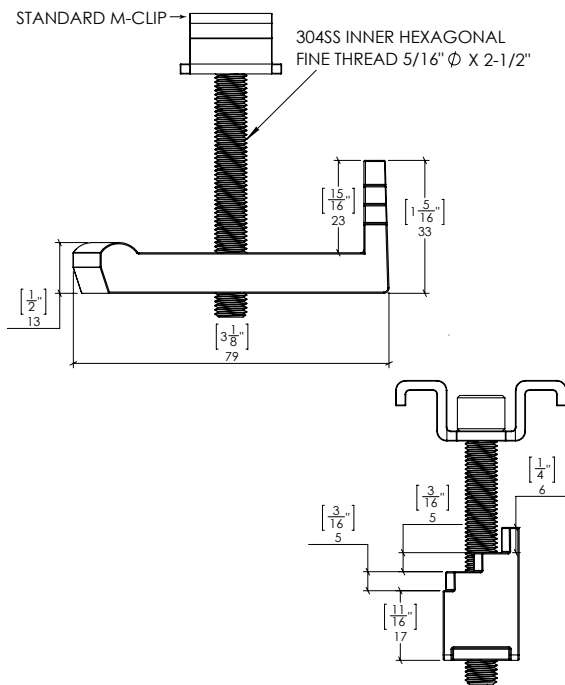

FASTENERS

Channel Grating Clips

J CLIP

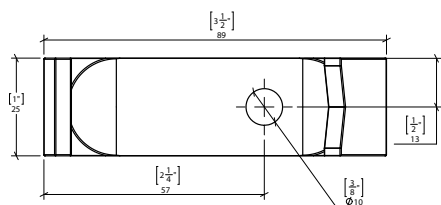

J-CLIP can be used in combination with a diamond or round clip.

Bolt and washers sold separately.

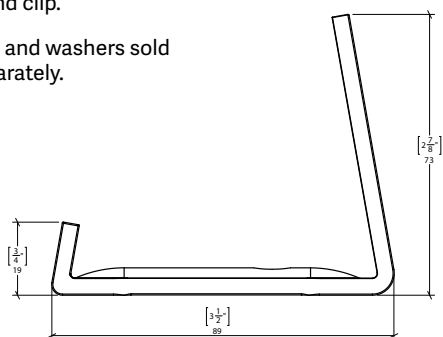

S CLIP

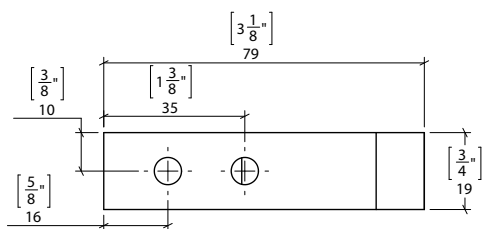

J-CLIP can be used in combination with a diamond or round clip.

Bolt and washers sold separately.

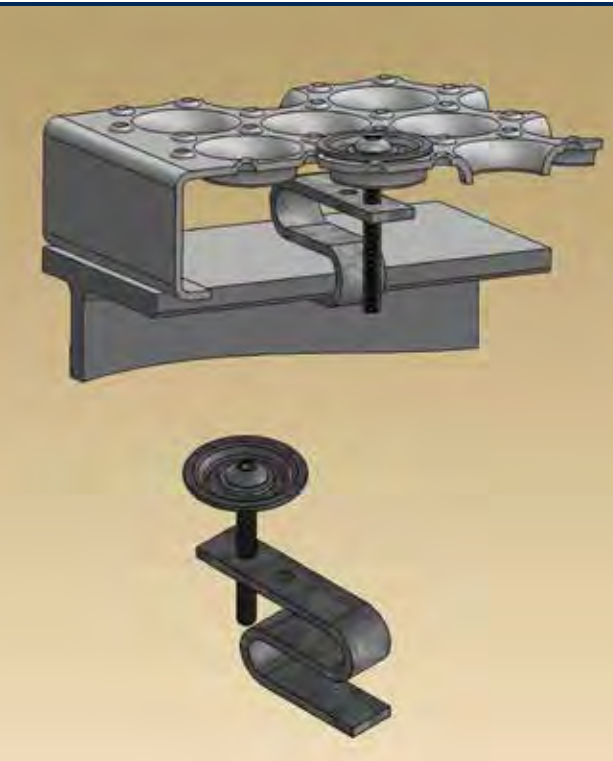
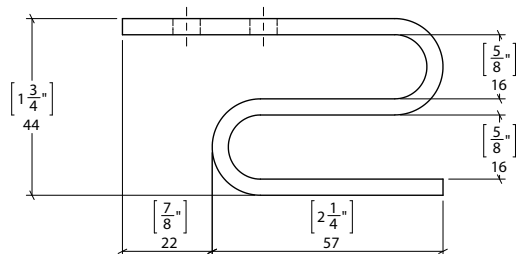

FASTENERS

Channel Grating Clips

MID-SPAN CLIP ASSEMBLY

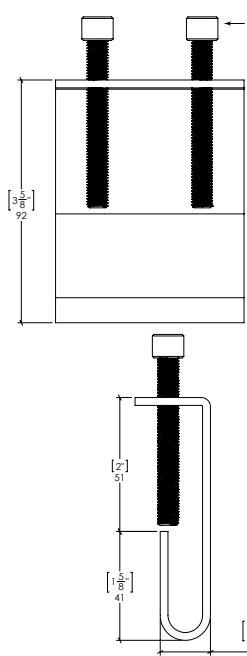

Acier inoxydable 304
hexagonal interne, filetage
fin de 5/16 po \varnothing x 2-1/2 po

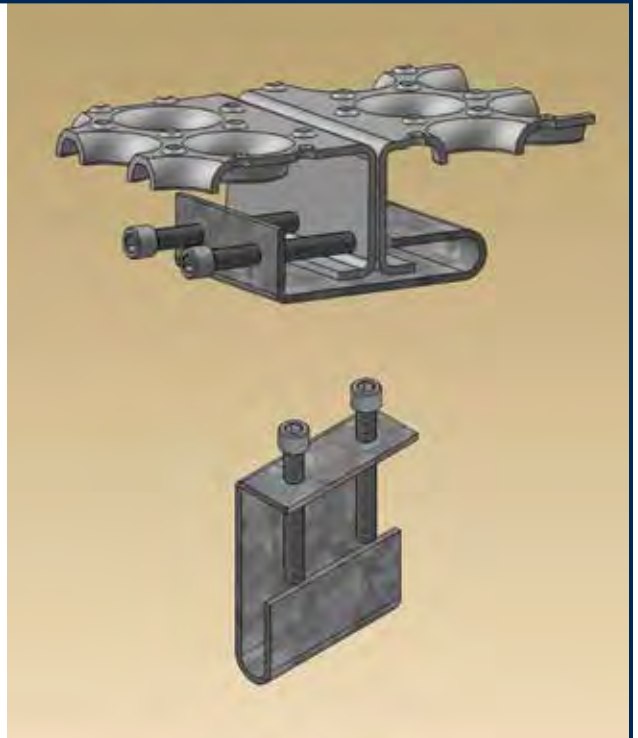

Fiberglass Grating Clips

FIBREGLASS M CLIP ASSEMBLY

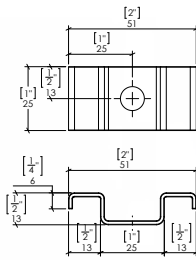

1/2" Attache en M pour fibre de verre

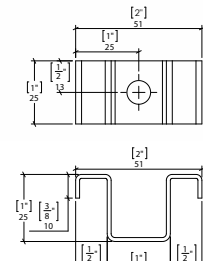

1" Attache en M pour fibre de verre

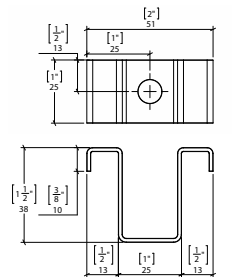

1-1/2" Attache en M pour fibre de verre

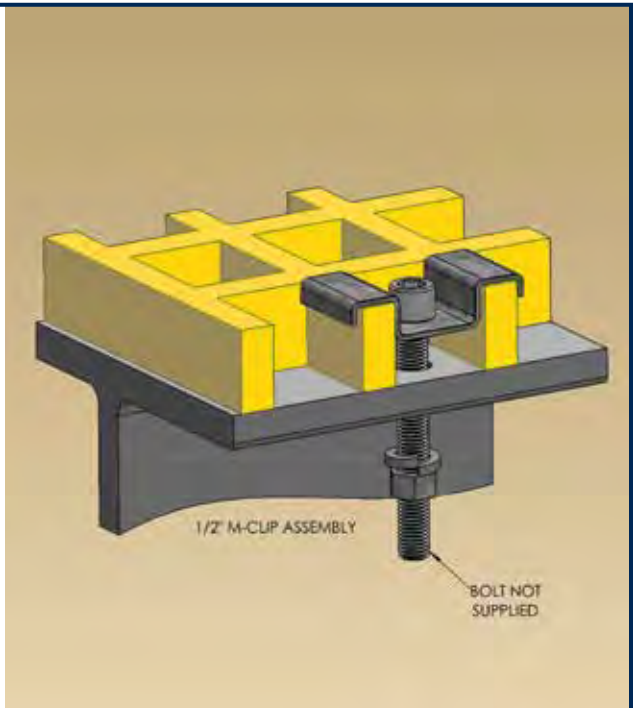

FASTENERS

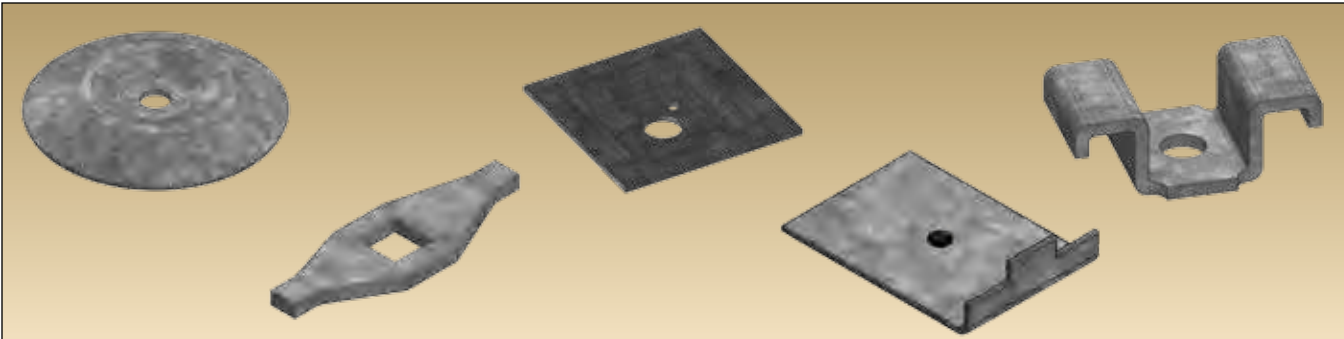

Clip assemblies are sold inclusive of all parts. However, should you require individual parts separate from assemblies, such as clips, screws and washers, we can help you with that as well. Ask your Accurate Screen Sales Representative for part availability and pricing.

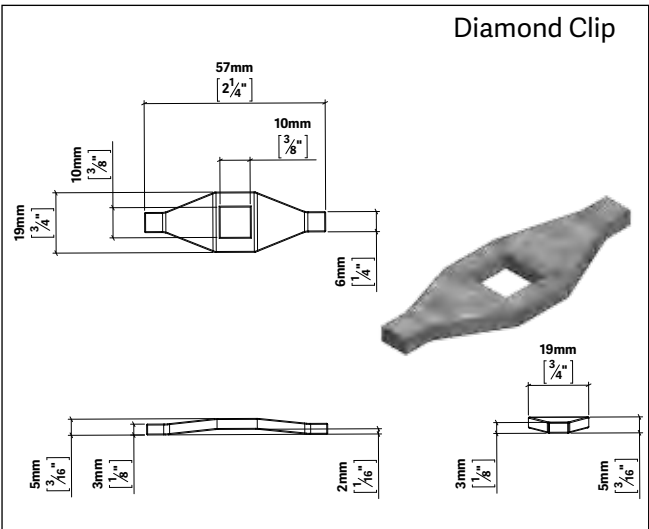
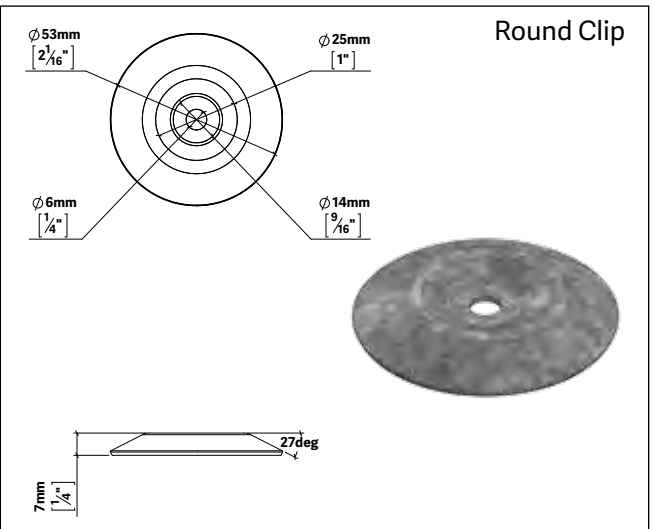
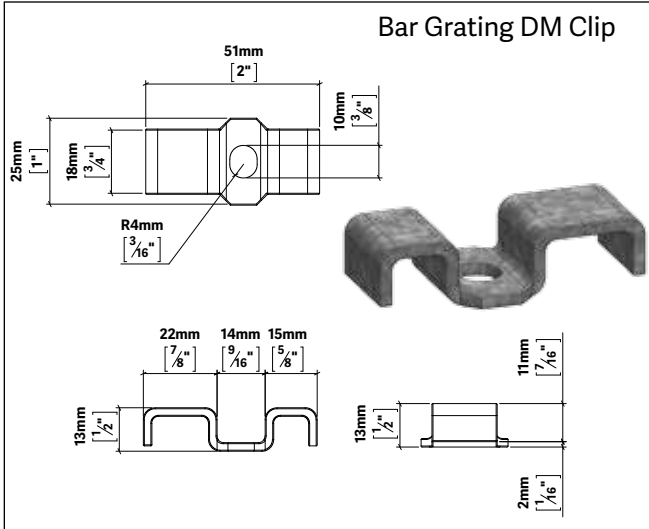
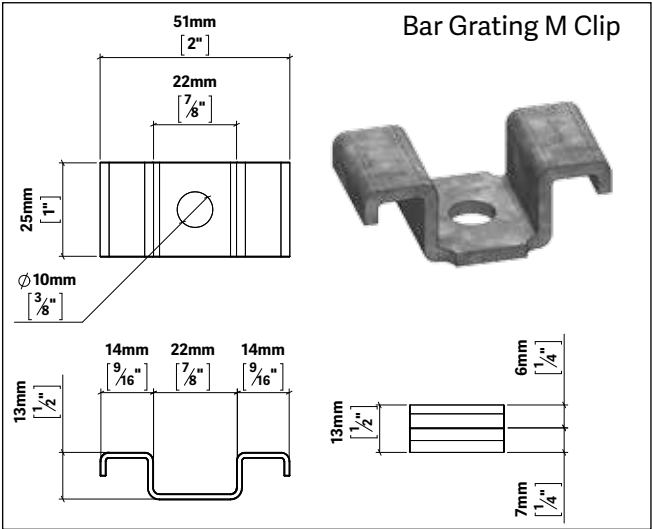

FASTENERS

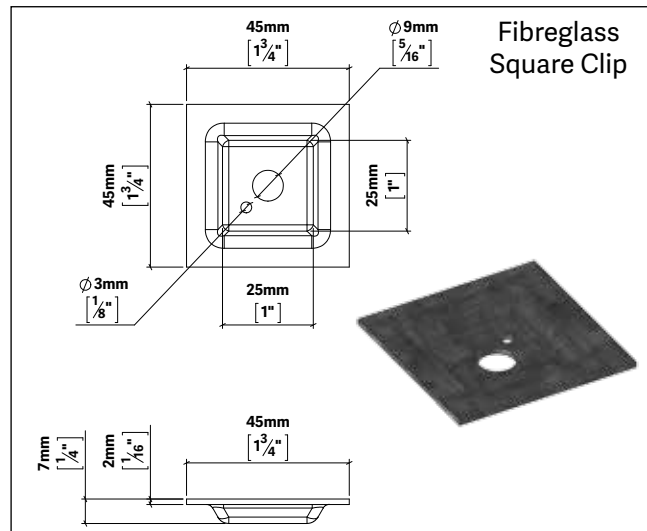
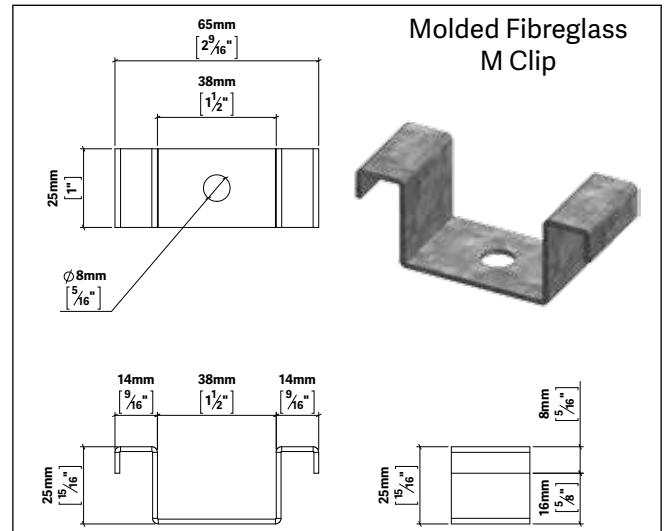
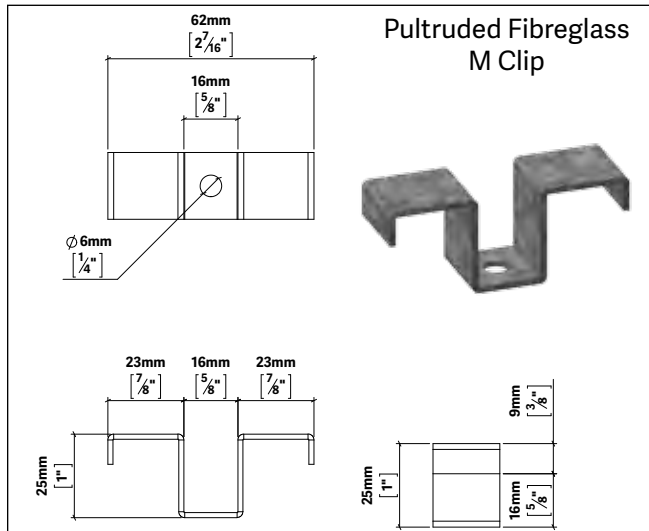

HEX SCREWS



BC-SCREW 2"

Hex Screw
1/4" x 2"
Self-Tap w/Sealing Washer.
JS500 coating

BC-SCREW 2-1/2"

Hex Screw
1/4" x 2-1/2"
Self-Tap w/Sealing Washer.
JS500 coating

BC-SS-SCREW 2"

Hex Screw
Stainless
1/4" x 2-1/2"
Self-Tap w/Sealing Washer.

ARCHITECTURAL



Fabrication

Perforated

Welded

Woven

Expanded

Bar Grating

Fibreglass

Channel Grating

ALU. Deck & Clad
Non-Slip Floor

Wire, Banding
& Fasteners

Architectural

EMBOSSED SHEET METAL



Embossed metal finishes have become statement design elements for unique interior and exterior facades. Accurate Screen carries a variety of patterns in mirror quality stainless steel and other alloys.

Below are a random sample of the patterns we carry. Other patterns, alloys and finishes are available. Speak with your Accurate Screen Sales Representative if you require additional information on available embossed metal choices for your next project.

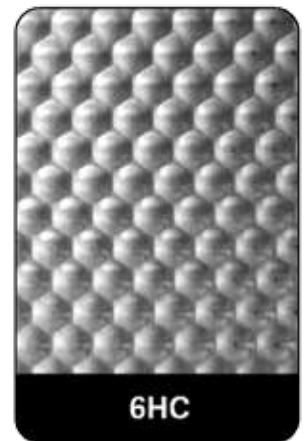
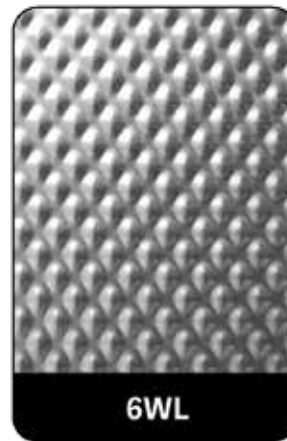
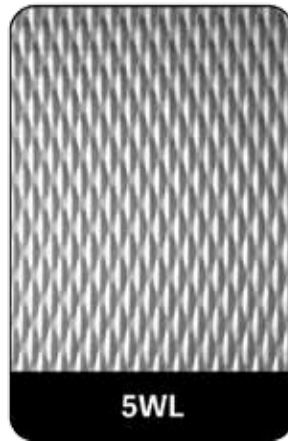
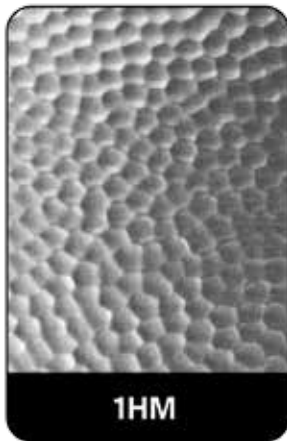

Pattern	Alloy	Finish	Gauge	Sheet Size
1HM	304ss	#4	22	3 x 10
5WL	304ss	#4	16	4 x 8
6WL	304ss	2b	22	4 x 10
6HC	304ss	#4	22	4 x 10
1SLG	304ss	2b	22	4 x 10
3QLT	304ss	#4	22	4 x 10
RSS3	304ss	#4	22	4 x 10
SandTex	304ss	#4	22	4 x 10

WOVEN WIRE MESH



These images demonstrate a few of the methods Woven Mesh can be used as a functional and decorative element in commercial and residential construction. Its strength, durability and paintability make it an excellent solution for these kinds of uses.

The product profile pictures shown below are a few of the custom woven meshes available. The majority of this material is made to order. Spacing, wire diameter and crimp styles are all customizable.

Please contact your Accurate Screen Sales Representative with your project requirements or with any questions regarding available product and specifications.

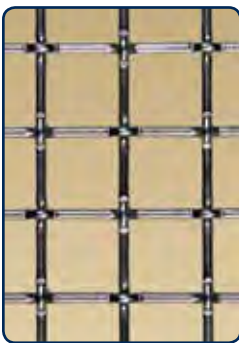

1 Mesh #101

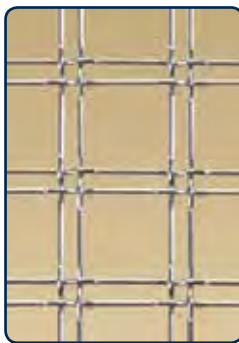

Argyl #102



Whistler #103

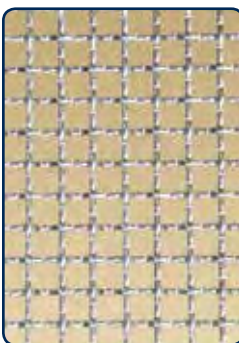

3 Mesh #104

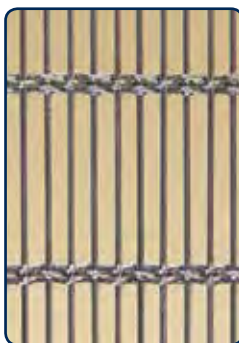

Tri-Cable #105



Selkirk #106



PERFORATED METAL

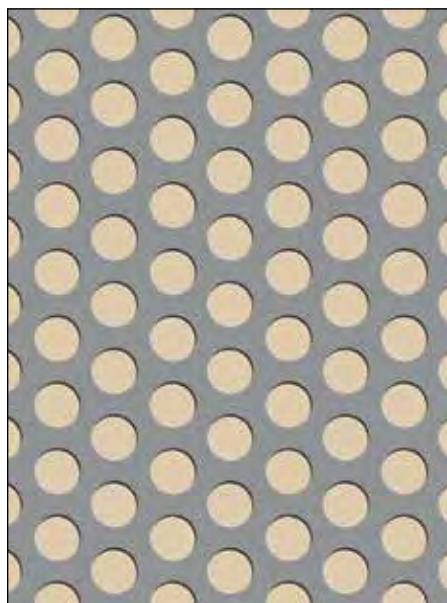

ROUND STAGGERED

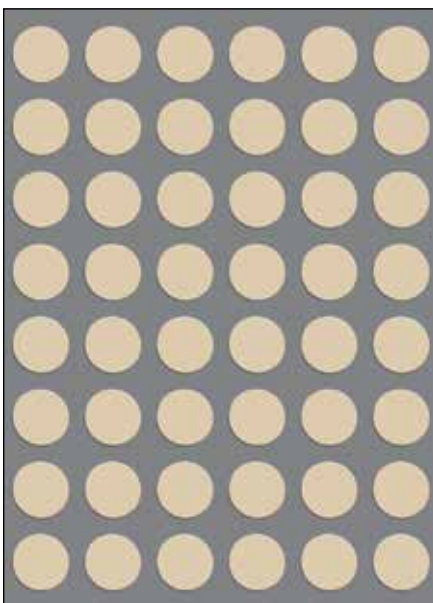

ROUND INLINE

Perforated metal is perhaps the most versatile product we carry. It has many industrial applications yet more and more it is being spec'd by interior designers and architects as a material for many residential and commercial construction projects. Its reflective qualities, variety of opening patterns and the durability it delivers make perforated metal an excellent choice for uniquely interesting surface applications.

Perforated metal is available in various alloys and thickness. Specific patterns may be dependant on alloy and gauge.

Speak with your Accurate Screen Sales Representative if you require assistance in determining pattern availability.

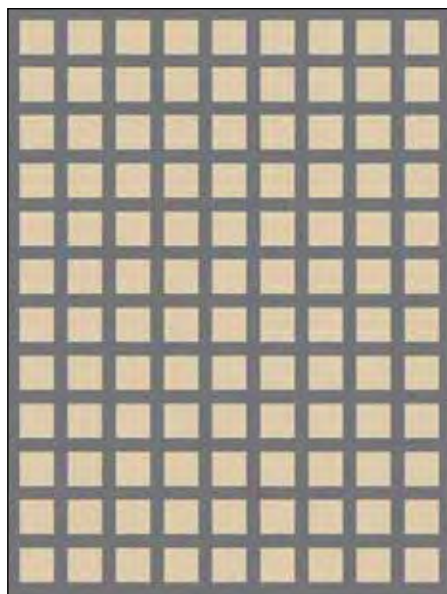

SQUARE INLINE



SLOTTED



GRECIAN

Refer to the Perforated Metal section of this catalogue, our website - www accuratescreen.ca or speak with your Accurate Screen Sales Representative for more information on our full Perforated Metal line-up.

www accuratescreen.ca

SHEET GAUGE CHART (Gauge to Decimal Equivalent in Inches)

Material								
Gauge	Steel		Galvanized		Stainless		Aluminum	
	Decimal Thickness	Lbs. per Sq/Ft.	Decimal Thickness	Lbs. per Sq/Ft.	Decimal Thickness	Lbs. per Sq/Ft.	Decimal Thickness	Lbs. per Sq/Ft.
32	0.0100		0.0130	.563	0.0100	.418	0.008	.115
31	0.0110		0.0140	.594	0.0109	.450	0.009	.130
30	0.0120	0.500	0.0157	.656	0.0125	.515	0.010	.144
29	0.0135	0.563	0.0172	.710	0.0140	.579	0.011	.158
28	0.0149	0.625	0.0187	.781	0.0156	.643	0.012	.173
27	0.0164	0.688	0.0202	.844	0.0171	.708	0.014	.202
26	0.0179	0.750	0.0217	.906	0.0187	.772	0.016	.230
25	0.0209	0.875	0.0247	1.031	0.0218	.901	0.018	.259
24	0.0239	1.000	0.0276	1.156	0.0250	1.030	0.020	.288
23	0.0269	1.125	0.0306	1.281	0.0281	1.158	0.022	.331
22	0.0299	1.250	0.0336	1.406	0.0312	1.287	0.025	.360
21	0.0329	1.375	0.0366	1.531	0.0343	1.416	0.028	.403
20	0.0359	1.500	0.0396	1.656	0.0375	1.545	0.032	.461
19	0.0418	1.750	0.0456	1.908	0.0437	1.802	0.036	.518
18	0.0478	2.000	0.0516	2.156	0.0500	2.060	0.040	.576
17	0.0538	2.250	0.0575	2.406	0.0562	2.317	0.045	.648
16	0.0598	2.500	0.0635	2.656	0.0625	2.575	0.050	.734
15	0.0678	2.812	0.0710	2.969	0.0703	2.896	0.058	.821
14	0.0747	3.125	0.0785	3.291	0.0781	3.218	0.063	.922
13	0.0897	3.750	0.0934	3.906	0.0937	3.862	0.071	1.040
12	0.1046	4.375	0.1084	4.531	0.1093	4.506	0.080	1.170
11	0.1196	5.000	0.1233	5.156	0.1250	5.150	0.090	1.310
10	0.1345	5.625	0.1382	5.781	0.1406	5.793	0.100	1.470
9	0.1494	6.250	0.1532	6.406	0.1562	6.437	0.112	1.640
8	0.1844	6.875	0.1681	7.031	0.1718	7.081	0.125	1.760
7	0.1793	7.500			0.1875	7.590	0.140	1.980
6							0.160	2.254
5							0.190	2.685

Perforated Metal

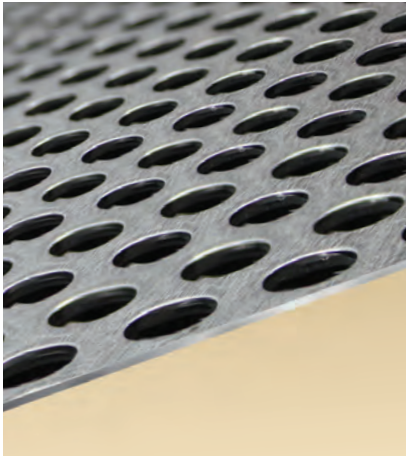

Woven Wire Mesh



Expanded Metal

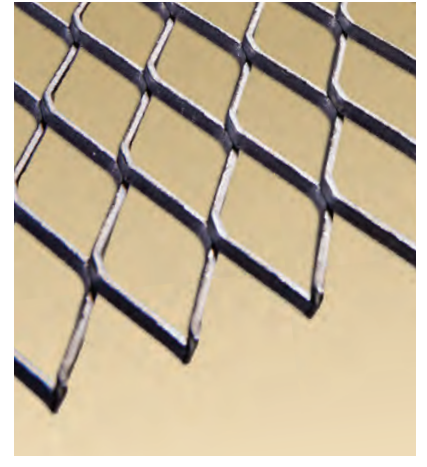

Welded Wire Mesh

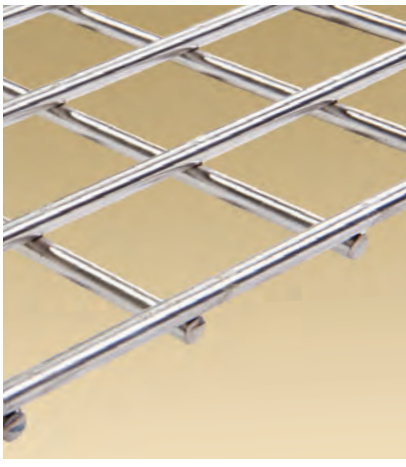

Channel Grating

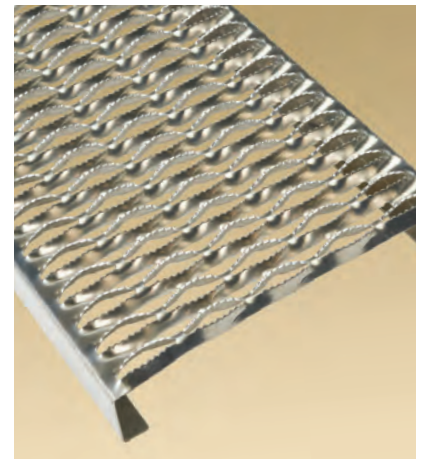

Fibreglass Grating

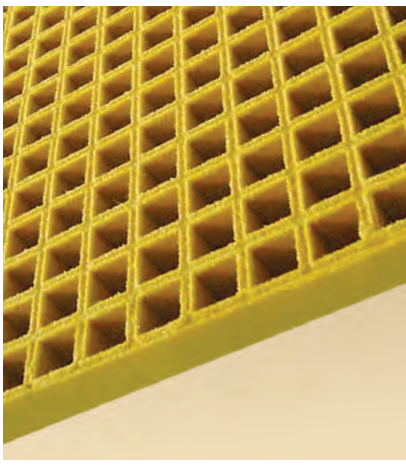

Aluminum Decking

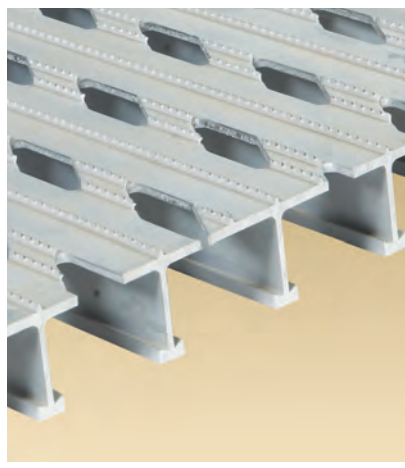

Bar Grating

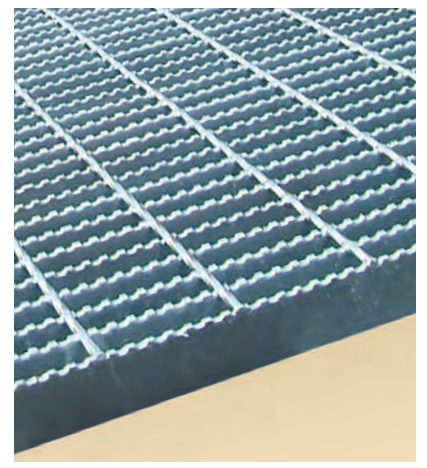

www accuratescreen.ca

CALGARY

TF: 877-857-0323

Local: 403-236-0703

TORONTO

TF: 877-564-3381

Local: 905-564-3381

VANCOUVER

TF: 877-687-8805

Local: 604-542-8805

MONTREAL

TF: 855-325-3826

Local: 514-325-3826

EDMONTON

TF: 877-857-0323

Local: 780-433-8024



Proudly Canadian
Serving
North America
since 2001